

No. of Pins		Dimension(mm)	
Single Row	Dual Row	L1	L2
002	004	4,00	2,00
003	006	6,00	4,00
004	008	8,00	6,00
005	010	10,00	8,00
006	012	12,00	10,00
007	014	14,00	12,00
008	016	16,00	14,00
009	018	18,00	16,00
010	020	20,00	18,00
011	022	22,00	20,00
012	024	24,00	22,00
013	026	26,00	24,00
014	028	28,00	26,00
015	030	30,00	28,00
016	032	32,00	30,00
017	034	34,00	32,00
018	036	36,00	34,00
019	038	38,00	36,00
020	040	40,00	38,00
021	042	42,00	40,00
022	044	44,00	42,00
023	046	46,00	44,00
024	048	48,00	46,00
025	050	50,00	48,00
026	052	52,00	50,00
027	054	54,00	52,00
028	056	56,00	54,00
029	058	58,00	56,00
030	060	60,00	58,00
031	062	62,00	60,00
032	064	64,00	62,00
033	066	66,00	64,00
034	068	68,00	66,00
035	070	70,00	68,00
036	072	72,00	70,00
037	074	74,00	72,00
038	076	76,00	74,00
039	078	78,00	76,00
040	080	80,00	78,00

Single Row

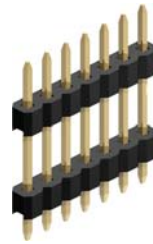

Dual Row

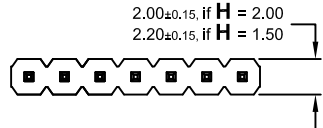
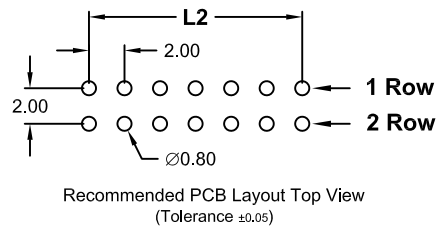
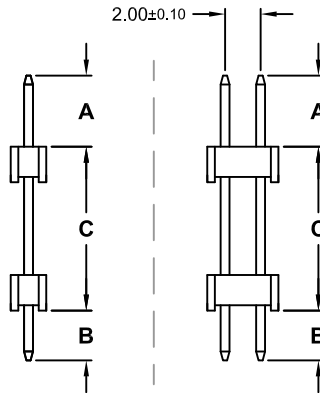
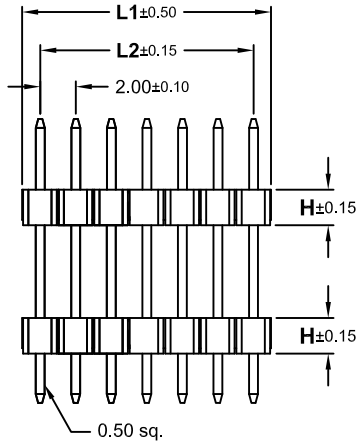
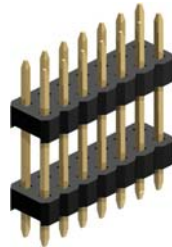
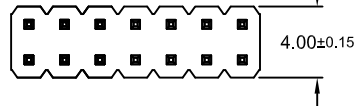

REV.	DESCRIPTION	DATE	DRAWN
A	New	01.11.2007	Ryan
E8	Add Pin Code "144/04"	01.02.2019	Cherry
E9	Add Pin Code "138/05"	10.05.2019	Cherry
E10	Add Pin Code "345/03"	27.06.2019	Cherry

Order Code

SPx-xxx-X xxx/xx -xx/2

Rows
Single Row = 1
Dual Row = 2

No. of Pins
Single Row = 002 to 040
Dual Row = 004 to 080

Excrcution
PBT Insulator (H:2.00mm) = S
PA Insulator (H:2.00mm) = N
PA Insulator (H:1.50mm) = B

Plating

Pin code	Plating
55	Gold flash (Standard)
66	5µ" Gold
77	10µ" Gold
88	30µ" Gold
99	Tin

Duplex plating
95 = Tin/Gold flash
96 = Tin/ 5µ" Gold
97 = Tin/10µ" Gold
98 = Tin/30µ" Gold



Specifications

Electrical

Current rating: 2A
Insulation resistance: 1000MΩ min.
Contact resistance: 20mΩ max.
Withstanding voltage: 500V AC / Minute

Materials

Contact: Brass
Plating: Gold, Tin or Duplex
*Duplex = Sn on solder, Au on contact area
Insulator: PBT or PA (black) UL 94V-0
Operating temperature: -40°C to +105°C

E-tec 2019 © - all rights reserved



UNIT	SCALE	GENERAL TOLERANCE	DRAWN	DATE	DWG. NO.	SHEET 1/2
mm	Free	X.° ±	Lyndon	09.03.2010	SPx-Xxxx/xx/2	REV. E10
		.X° ±	RONNY	27.06.2019	SERIES NO.	
		.XX° ±	HOGI	27.06.2019	SPx-xxx-Xxxx/xx-xx/2	
		.XXX° ±				

2.00mm Pitch Board Spacer

-THT- Straight

Single & Dual Row

Pin Code	Dim"A" (mm)	Dim"B" (mm)	Dim"C" (mm)	Pin Code	Dim"A" (mm)	Dim"B" (mm)	Dim"C" (mm)	Pin Code	Dim"A" (mm)	Dim"B" (mm)	Dim"C" (mm)	Pin Code	Dim"A" (mm)	Dim"B" (mm)	Dim"C" (mm)
100/08	3.20	3.20	3.60	143/04	4.80	2.50	7.00	282/03	9.10	6.10	13.00	295/02	6.00	2.50	21.00
100/06	4.00	2.00	4.00	200/02	10.00	3.00	7.00	210/11	4.50	3.00	13.50	301/01	6.00	3.10	21.00
105/07	4.00	2.50	4.00	330/02	23.00	3.00	7.00	282/04	7.40	7.30	13.50	290/10	6.20	1.80	21.00
170/05	6.70	6.30	4.00	143/01	4.00	2.80	7.50	194/02	2.70	2.70	14.00	292/01	6.30	1.90	21.00
138/05	7.70	1.70	4.40	143/03	2.40	3.90	8.00	200/03	3.00	3.00	14.00	328/03	8.30	3.50	21.00
144/04	7.70	2.30	4.40	142/16	3.10	3.10	8.00	205/02	4.00	2.50	14.00	340/12	10.70	2.30	21.00
155/10	4.00	7.00	4.50	160/05	4.00	4.00	8.00	210/08	4.00	2.30	14.70	341/01	10.80	2.30	21.00
102/03	4.00	1.50	4.70	164/05	5.90	2.50	8.00	215/02	4.00	2.80	14.70	280/01	3.00	3.00	22.00
108/14	4.00	2.10	4.70	198/08	5.90	5.90	8.00	282/02	7.50	6.00	14.70	310/01	6.00	3.00	22.00
138/04	6.80	2.30	4.70	200/04	6.00	6.00	8.00	211/10	3.30	2.80	15.00	378/07	7.90	7.90	22.00
143/02	6.80	2.80	4.70	220/03	7.00	7.00	8.00	240/03	6.00	3.00	15.00	332/01	5.00	2.80	25.40
104/01	2.70	2.70	5.00	168/02	6.00	2.50	8.30	265/07	9.20	2.30	15.00	330/04	4.00	3.00	26.00
150/04	6.00	4.00	5.00	150/01	4.00	2.50	8.50	220/01	4.00	2.80	15.25	410/01	9.00	4.00	28.00
315/04	23.50	3.00	5.00	280/02	16.50	2.50	9.00	245/05	6.00	3.00	15.50	345/03	3.00	2.80	28.70
136/02	5.30	3.20	5.10	173/03	5.20	2.80	9.30	225/02	4.00	2.80	15.70	375/01	4.00	3.00	30.50
137/02	2.80	5.70	5.20	157/01	3.60	2.60	9.50	252/02	5.20	4.20	15.80	378/08	4.00	3.10	30.70
116/09	3.90	2.40	5.30	163/01	4.00	2.80	9.50	275/01	9.20	2.30	16.00	428/01	7.00	2.80	33.00
130/04	4.50	3.00	5.50	180/03	5.00	3.00	10.00	281/01	7.20	4.80	16.10	425/01	4.00	4.00	34.50
155/13	5.00	5.00	5.50	188/02	6.00	2.80	10.00	221/01	2.80	2.80	16.50	425/03	4.00	2.00	36.50
145/01	6.20	2.80	5.50	200/07	7.00	3.00	10.00	300/03	10.00	3.00	17.00	432/01	3.20	3.20	36.80
191/01	9.30	4.30	5.50	175/03	4.00	3.00	10.50	225/01	2.50	2.50	17.50	522/01	4.00	4.00	44.20
125/18	4.00	2.80	5.70	320/03	14.50	7.00	10.50	235/06	3.50	2.50	17.50	583/01	7.00	7.00	44.30
117/03	3.50	2.20	6.00	186/06	4.00	4.00	10.60	282/01	7.40	3.00	17.80	590/01	3.00	3.00	53.00
119/01	3.50	2.40	6.00	202/03	4.70	4.70	10.80	313/02	10.70	2.80	17.80				
120/02	3.50	2.50	6.00	226/01	7.80	4.00	10.80	253/01	5.00	2.30	18.00				
134/03	4.60	2.80	6.00	170/01	3.00	3.00	11.00	263/03	6.00	2.30	18.00				
160/12	5.00	5.00	6.00	210/02	7.00	3.00	11.00	293/02	7.30	3.00	19.00				
200/05	7.00	7.00	6.00	191/04	4.20	3.70	11.20	245/02	3.00	2.30	19.20				
210/12	9.00	6.00	6.00	220/02	7.00	3.50	11.50	281/02	4.20	4.00	19.90				
216/17	12.00	3.60	6.00	180/02	3.00	3.00	12.00	256/01	2.80	2.80	20.00				
117/01	2.80	2.80	6.10	179/02	3.50	2.40	12.00	270/02	4.00	3.00	20.00				
152/01	6.00	3.00	6.20	210/01	6.00	3.00	12.00	270/08	3.70	2.30	21.00				
126/06	2.80	2.80	7.00	191/02	4.11	2.54	12.45	283/02	3.70	3.60	21.00				
180/11	3.00	8.00	7.00	180/04	2.50	2.50	13.00	286/01	6.00	1.60	21.00				
140/15	4.50	2.50	7.00	260/04	9.00	4.00	13.00	295/01	5.40	3.10	21.00				

E-tec 2019 © - all rights reserved



UNIT	mm	GENERAL TOLERANCE	
	SCALE	.X° ±	.X ±
		.XX° ±	.XX ±
		.XXX° ±	.XXX ±

DRAWN	Lyndon	DATE	09.03.2010
CHECK	Ronny	DATE	27.06.2019
APPROVE	Hogi	DATE	27.06.2019

DWG. NO.	SPx-Xxxx/xx/2	SHEET 2/2
SERIES NO.	SPx-xxx-Xxxx/xx-xx/2	REV. E10

Pin Code Sheet
for 2.00mm Pitch Board Spacer
-THT- Straight
Single & Dual Row