

REV.	DESCRIPTION	DATE	DRAWN
A	Release	01.07.2009	Ronny
B	New DWG. No.	01.02.2012	Ronny
C	update; add LED polarity	13.02.2015	Ronny

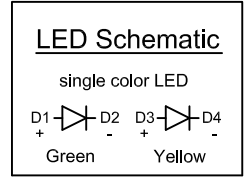

**Recommended PCB Hole Layout  
Top View**  
(PCB TOLERANCE ±0.05)

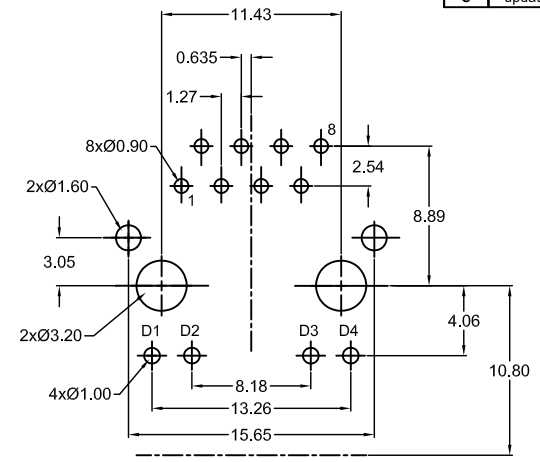
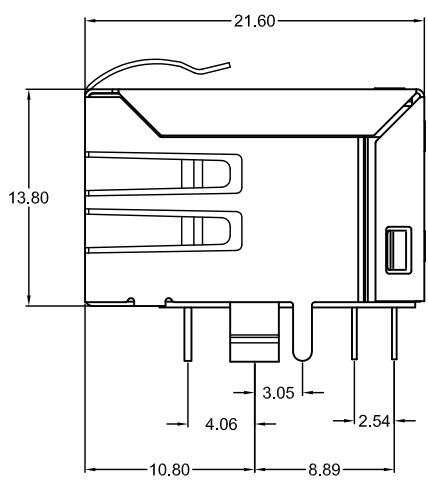
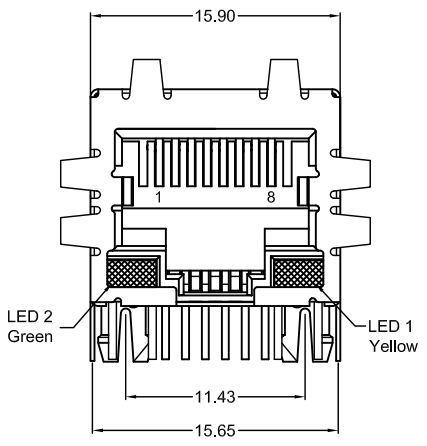
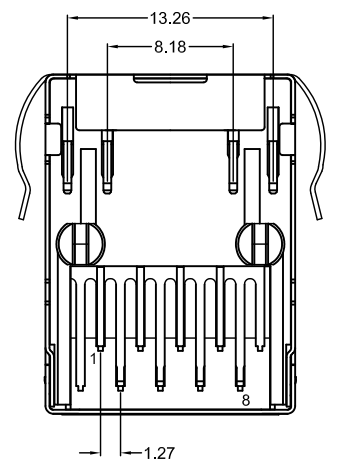

**Schematic: LE Type**  
(Standard for Ethernet)

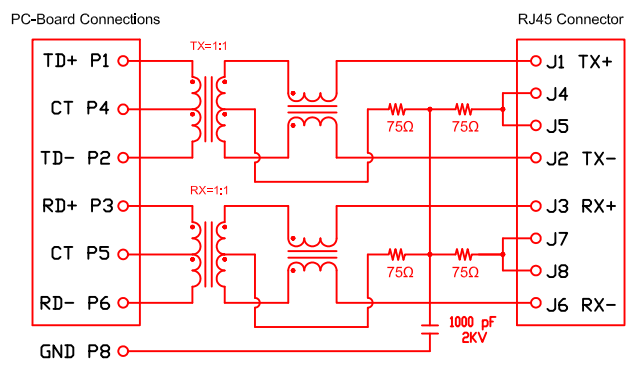

- ELECTRICAL CHARACTERISTICS**  
Test Notes: (25°C ±5°C)
- TR: (100KHz 0.1V):  
Pins: (P1-P2);(J1-J2)=1:1±3%  
Pins: (P3-P6);(J3-J6)=1:1±3%
  - LX: (100KHz 100mV 8mA DC Bias)  
Pins: (P1-P2);(P3-P6)=350µH min.
  - DCR:  
Pins: (J1-J2);(J3-J6)=1.2Ω max.
  - HIPOT:  
Pins: (P1,P2)to(J1,J2)=1500V AC for 60 Sec.  
Pins: (P3,P6)to(J3,J6)=1500V AC for 60 Sec.
  - INSERTION LOSS:  
-1.0dB max. at 1MHz to 100MHz
  - RETURN LOSS:  
-18dB min. at 1MHz to 30MHz (load 100Ω)  
-16dB min. at 30MHz to 60MHz (load 100Ω)  
-12dB min. at 60MHz to 80MHz (load 100Ω)
  - CROSS TALK:  
-30dB min. at 1MHz to 100MHz
  - COMMON TO COMMON MODE REJECTION:  
-30dB min. at 1MHz to 100MHz

**SPECIFICATION**

- MATERIAL:**  
Housing - PBT UL 94V-0 (black)  
Contact - 0.35mm PhBz; Au/Sn plated  
Shield - Brass; Ni plated
- OPERATING LIFE:** 750 Cycles min.
- TEMPERATURE RANGE:**  
Storage - -40°C to +85°C  
Operating - 0°C to 70°C
- Cavity comply with FCC Rules and Regulations Part 68, Subpart F

PART NUMBER	GOLD PLATING CONTACT AREA
MJS-188-M0LE-95/74CA	3µ"
MJS-188-M0LE-96/74CA	6µ"
MJS-188-M0LE-97/74CA	15µ"
MJS-188-M0LE-98/74CA	30µ"
MJS-188-M0LE-9H/74CA	50µ"



UNIT mm SCALE Free	GENERAL TOLERANCE	DRAWN Ronny	DATE 01.07.2009	DWG. NO. 1342504	SHEET 1/1
	X.° ± 3°	CHECK Ronny	DATE 13.02.2015	Series NO. MJS-188-M0LE-9x/74CX	REV. C
	X. ±	APPROVE Hogi	DATE 13.02.2015		
	XX. ±				

**RJ 45 PCB JACK <8P8C>**  
**SIDE ENTRY-LONG PROFILE TYPE with LED**  
**FULLY SHIELDED w GRD. LATCHES AROUND**  
**"LE" Type 10/100 Base TX Filtered (Standard for Ethernet)**

REV.	LOCAS.	DESCRIPTION	DATE	DRAWN
A		NEW	21.10.2008	RH
B		LED Nbr. & PN /74CA → /71CA	01.07.2009	Ronny
C		New DWG. No.	01.02.2012	Ronny

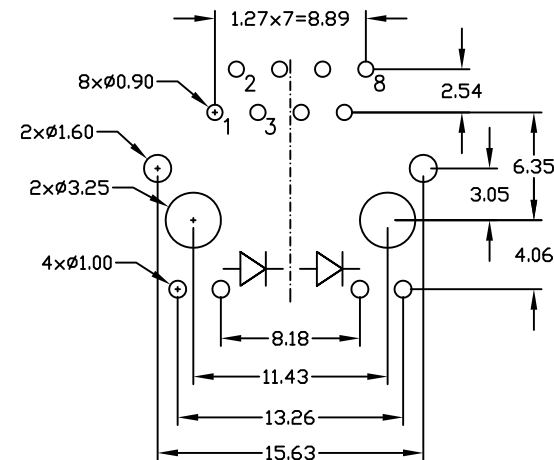
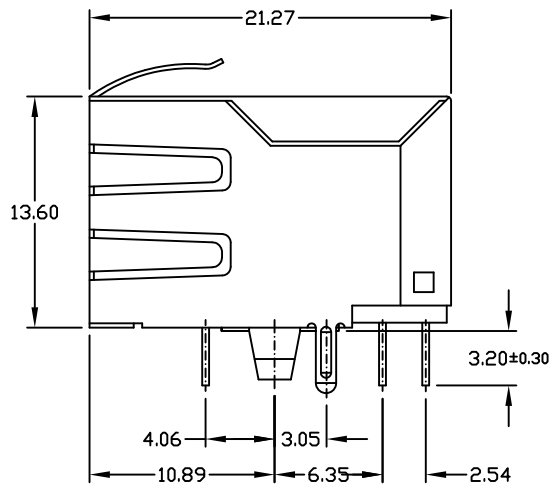
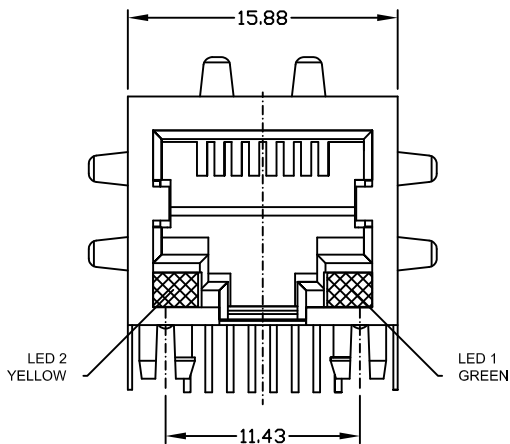

### ELECTRICAL Transmitter filter

Type: Balance low pass 100Ω impedance  
 Insertion loss: 1~100MHz -1.15dB max.  
 Return loss: 1~30MHz -18dB min. Load 100Ω  
 30~60MHz -15dB min. Load 100Ω  
 60~80MHz -11dB min. Load 100Ω

### Receiver filter

Type: Balance low pass 100Ω impedance  
 Insertion loss: 1~100MHz -1.0dB max.  
 Return loss: 1~30MHz -20dB min. Load 100Ω  
 30~60MHz -14dB min. Load 100Ω  
 60~80MHz -12dB min. Load 100Ω

### Common mode Rejection @ 1~100MHz -25dB min.

### Cross Talk @ 1~100MHz -28dB min.

### Inductance @ 100KHz, 0.1V, 8mA DC BIAS Input (1-3), Input (7-8): 350µH min.

### Hi-Pot TEST Input (1-3) to Output (1-2): 1500V AC, 60sec. Input (7-8) to Output (3-6): 1500V AC, 60sec.

### SPECIFICATIONS

Current rating: 1.5A  
 Insulation resistance: 500MΩ min./500V DC  
 Dielectric withstanding: 1000V rms. 60Hz/Minute  
 Contact resistance: 40mΩ max./20mV DC  
 Operating temperature: -40°C ~ +105°C  
 Insulator material: High temp. thermoplastic  
 UL94V-0 color: Black  
 Contact material: Phosphor Bronze  
 Finish: Gold plated on contact area,  
 Tin on solder area  
 Shielded: Brass, Nickel plated

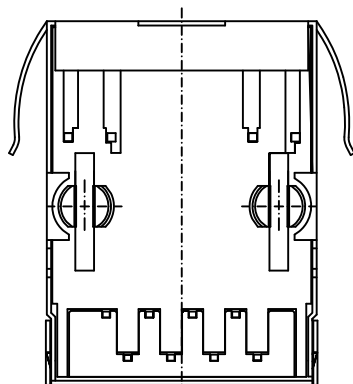

### L0 Type

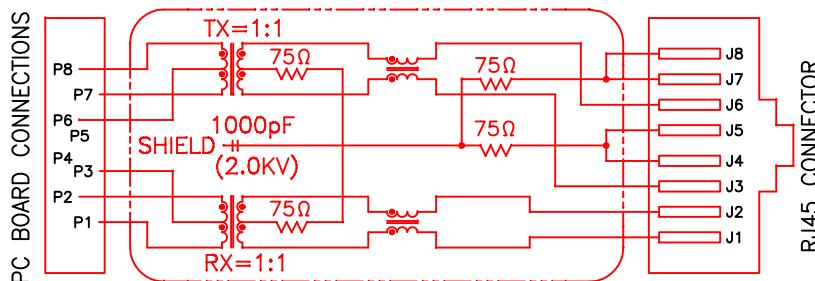

PART NUMBER	GOLD PLATING CONTACT AREA
MJS-188-M1L0-96/71CA	6µ"
MJS-188-M1L0-97/71CA	15µ"
MJS-188-M1L0-98/71CA	30µ"
MJS-188-M1L0-9H/71CA	50µ"

UNIT	SCALE	GENERAL TOLERANCE	DRAWN	DATE	DWG. NO.	SHEET 1/1
mm	Free	X.° ± X. ± 0.50	RONNY	21.10.2008	1342506	REV. C
		.X° ± .X ± 0.38	Ronny	01.02.2012	SERIES NO.	
		.XX° ± .XX ± 0.25	APPROVE	DATE	MJS-188-X1Lx-xx/7xCX	
		ANG ± 3° .XXX ± 0.10	HOGI	01.02.2012		

**RJ45 PCB JACK <8P8C> with lower LED  
 SIDE ENTRY-LONG PROFILE TYPE  
 FULLY SHIELDED with grd.latches around  
 L0 Type 10/100 Base TX Filtered**



REV.	LOCAS.	DESCRIPTION	DATE	DRAWN
A		NEW	02.06.2009	RH
B		LED Nbr. & PN /74CS -> /71CS	01.07.2009	Ronny
C		New DWG. No.	01.02.2012	Ronny

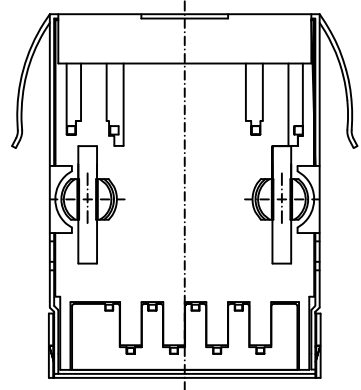
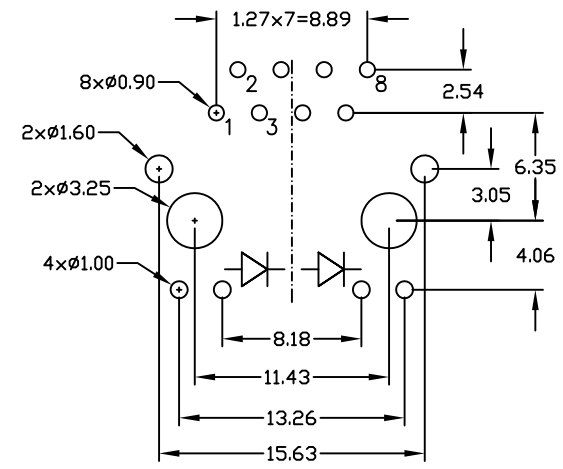
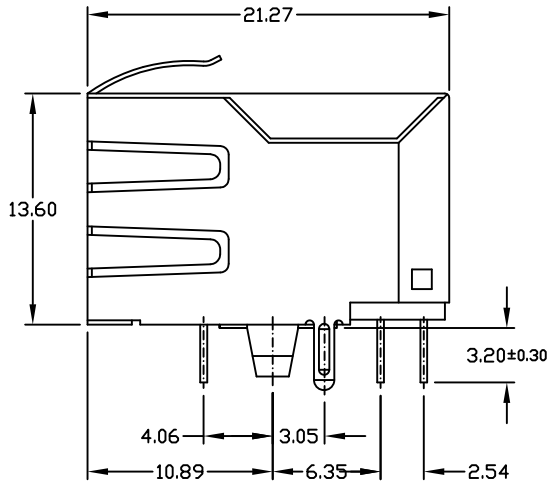
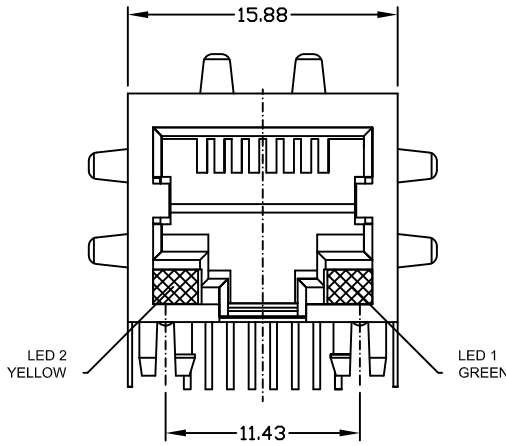

### SPECIFICATIONS

Current rating: 1.5A  
 Insulation resistance: 500MΩ min./500V DC  
 Dielectric withstanding: 1000V rms. 60Hz/Minute  
 Contact resistance: 40mΩ max./20mV DC  
 Operating temperature: -40°C ~ +105°C  
 Insulator material: High temp. thermoplastic  
 UL94V-0 color: Black

Contact material: Phosphor Bronze  
 Finish: Gold plated on contact area, Tin on solder area  
 Shielded: Brass, Nickel plated



### ELECTRICAL

#### Transmitter filter

Type: Balance low pass 100Ω impedance  
 Insertion loss: 1~100MHz -1.15dB max.  
 Return loss: 1~30MHz -18dB min. Load 100Ω  
 30~60MHz -15dB min. Load 100Ω  
 60~80MHz -11dB min. Load 100Ω

#### Receiver filter

Type: Balance low pass 100Ω impedance  
 Insertion loss: 1~100MHz -1.0dB max.  
 Return loss: 1~30MHz -20dB min. Load 100Ω  
 30~60MHz -14dB min. Load 100Ω  
 60~80MHz -12dB min. Load 100Ω

#### Common mode Rejection

@ 1~100MHz -25dB min.

#### Cross Talk

@ 1~100MHz -28dB min.

#### Inductance

@ 100KHz, 0.1V, 8mA DC BIAS  
 Input (1-3), Input (7-8): 350µH min.

#### Hi-Pot TEST

Input (1-3) to Output (1-2): 1500V AC, 60sec.  
 Input (7-8) to Output (3-6): 1500V AC, 60sec.

PART NUMBER	GOLD PLATING CONTACT AREA
MJS-188-M1L2-96/71CA	6µ"
MJS-188-M1L2-97/71CA	15µ"
MJS-188-M1L2-98/71CA	30µ"
MJS-188-M1L2-9H/71CA	50µ"

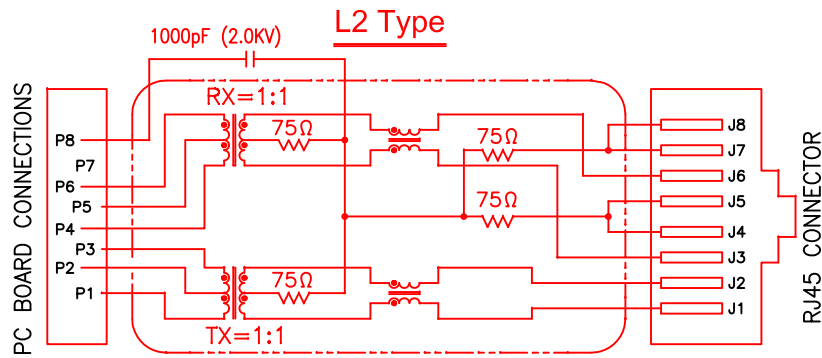

UNIT	SCALE	GENERAL TOLERANCE	DRAWN	DATE	DWG. NO.	SHEET 1/1
mm	Free	X.° ± X. ± 0.50	Ronny	02.06.2009	1342510	REV. C
		.X° ± .X ± 0.38	Ronny	01.02.2012	SERIES NO.	
		.XX° ± .XX ± 0.25	HOGI	01.02.2012	MJS-188-X1Lx-xx/7xCX	
		ANG ± 3°				

**RJ45 PCB JACK <8P8C> with lower LED SIDE ENTRY-LONG PROFILE TYPE FULLY SHIELDED with grd.latches around L2 Type 10/100 Base TX Filtered**

REV.	LOCAS.	DESCRIPTION	DATE	DRAWN
A		NEW	28.02.2012	Ronny

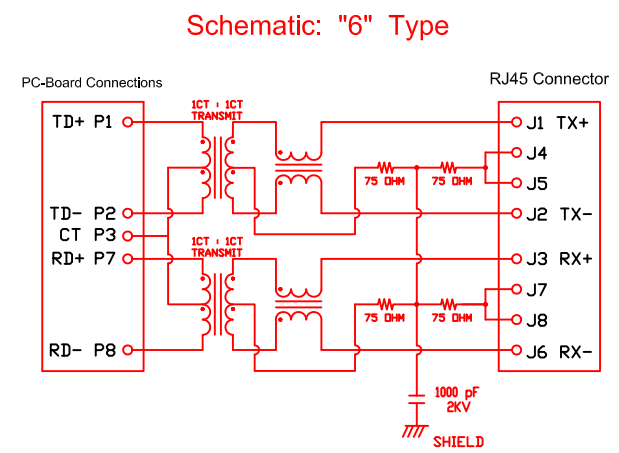
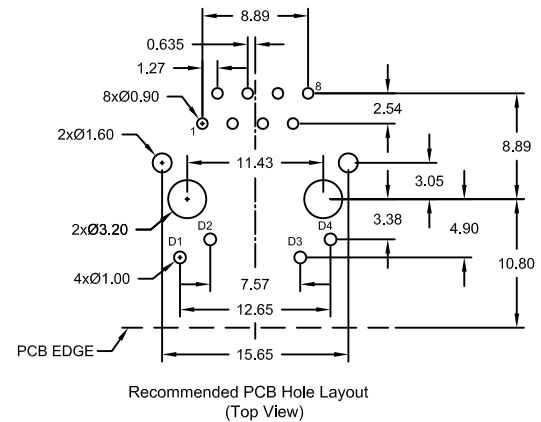
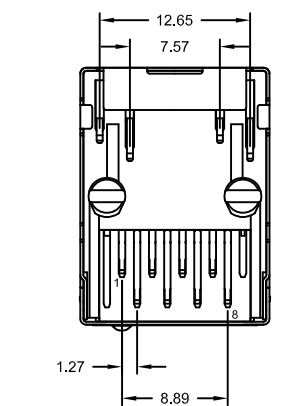
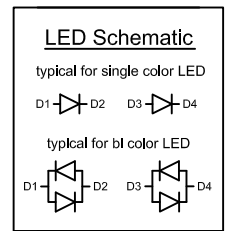
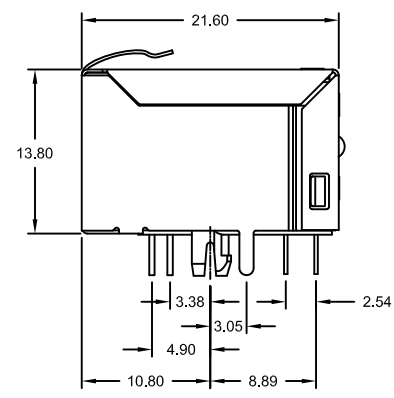
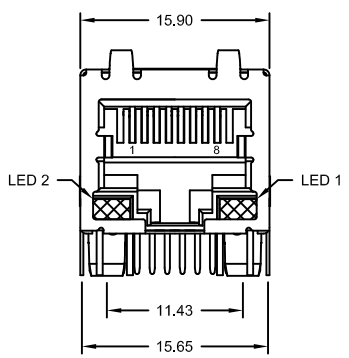

**ELECTRICAL CHARACTERISTICS**

- Test Notes: (25°C ±5°C)
- TR: (100KHz 0.1V):  
Pins: (P1-P2);(J1-J2)=1:1±3%  
Pins: (P7-P8);(J3-J6)=1:1±3%
  - LX: (100KHz 100mV 8mA DC Bias)  
Pins: (P1-P2);(P7-P8)=350µH min.
  - DCR:  
Pins: (J1-J2);(J3-J6)=1.2Ω max.
  - HIPOT:  
Pins: (P1,P2)to(J1,J2)=1500V AC for 60 Sec. or 2250V DC 60 Sec.  
Pins: (P7,P8)to(J3,J6)=1500V AC for 60 Sec. or 2250V DC 60 Sec.



**SPECIFICATION**

**MATERIALS**

Insulator: PBT UL 94V-0  
 Contact: 0.35mm Copper Alloy  
 plated with Gold, and Tin in solder area  
 Shield: Brass, Nickel plated  
 Operating Temperature: 0°C to ~+70°C

Replace "x" with LED Color Options

	LED Color Options	
	LED 2	LED 1
1	YELLOW	GREEN
2	NO LED	GREEN
3	GREEN	NO LED
4	GREEN	YELLOW
5	GREEN	GREEN
6	YELLOW	YELLOW
7	ORANGE/GREEN	ORANGE/GREEN
8	YELLOW/GREEN	YELLOW/GREEN
9	RED	NO LED
A	GREEN/YELLOW	GREEN/YELLOW
B	RED/GREEN	RED/GREEN
C	RED/GREEN	GREEN/YELLOW
D	GREEN	GREEN/YELLOW
E	YELLOW	GREEN/YELLOW

PART NUMBER	GOLD PLATING CONTACT AREA
MJS-188-K0L6-95/7xCT	3µ"
MJS-188-K0L6-96/7xCT	6µ"
MJS-188-K0L6-97/7xCT	15µ"
MJS-188-K0L6-98/7xCT	30µ"
MJS-188-K0L6-9H/7xCT	50µ"



UNIT	GENERAL TOLERANCE		DRAWN	DATE	DWG. NO.	SHEET 1/1
mm	X.° ±	X. ±	Ronny	28.02.2012	1342514	REV. A
SCALE	.X° ±	.X ± 0.25	CHECK	DATE	SERIES NO.	
Free	.XX° ±	.XX ± 0.15	Ronny	28.02.2012	MJS-188-K0L6-9x/7xCT	
	.XXX° ±	.XXX ± 0.075	APPROVE	DATE		
			Hogi	28.02.2012		

**RJ45 PCB JACK <8P/8C>**  
 side entry, long profile Type with LED  
 fully shielded, with top Grd. Latches around  
**6 Type** 10/100 Mbps, 4 core TX Filtered

REV.	LOCAS.	DESCRIPTION	DATE	DRAWN
A		NEW	27.06.2012	Ronny

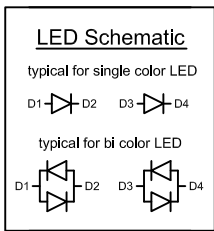
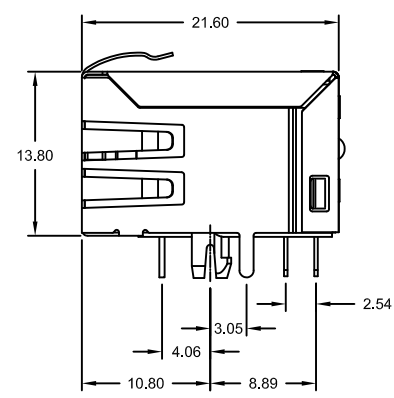
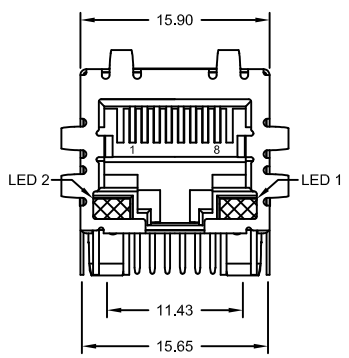

**Schematic: "H" Type**

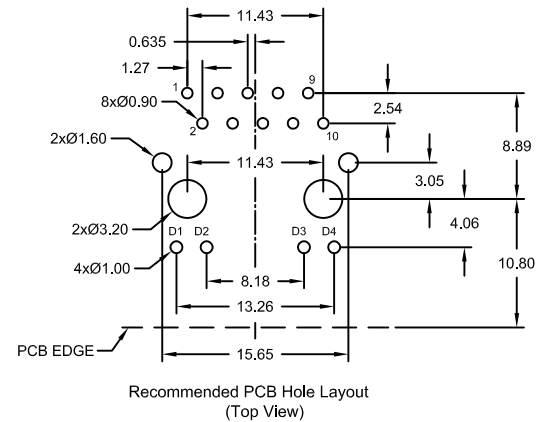
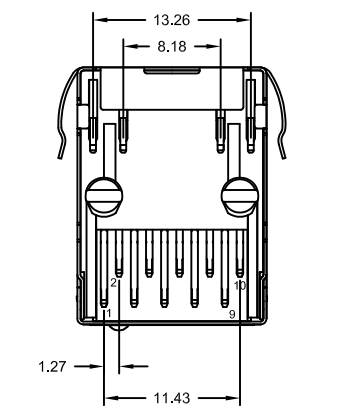
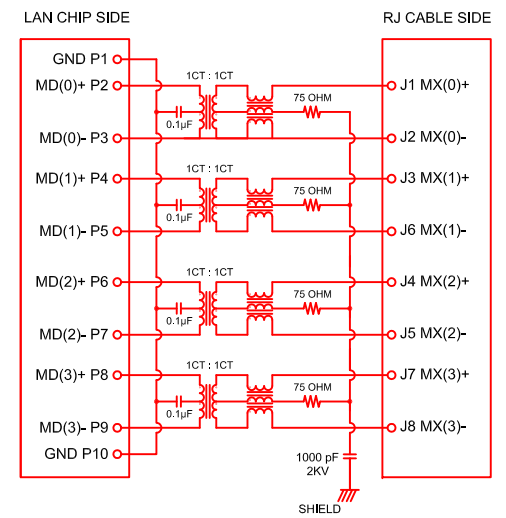

**ELECTRICAL CHARACTERISTICS**

- Test Notes: (25°C ±5°C)
- TR: (100KHz 0.1V);  
Pins: (P2,P3):(J1-J2)=1:1±3%;(P4,P5):(J3,J6)=1:1±3%;  
Pins: (P6,P7):(J4-J5)=1:1±3%;(P8,P9):(J7,J8)=1:1±3%
  - LX: (100KHz 100mV 8mA DC Bias)  
Pins: (P2,P3),(P4-P5),(P6,P7),(P8-P9)=350µH min.
  - DCR:  
Pins: (J1-J2),(J3-J6),(J4,J5),(J7,J8)=1.2Ω max.
  - HIPOT:  
Pins: (P2,P3)to(J1,J2),(P4,P5)to(J3,J6)=1500V AC for 60 Sec. or 2250V DC 60 Sec.  
Pins: (P6,P7)to(J4,J5),(P8,P9)to(J7,J8)=1500V AC for 60 Sec. or 2250V DC 60 Sec.
  - INSERTION LOSS:  
-0.8dB max. at 0.3MHz to 100MHz  
-1.2dB max. at 100MHz to 120MHz
  - RETURN LOSS:  
-18dB min. at 0.5MHz to 40MHz;  
-12+20 Log (f/80MHz)dB min. at 40MHz to 100MHz
  - CROSS TALK:  
-33+20 Log (f/100MHz)dB min. at 0.1MHz to 100MHz
  - COMMON TO DIFFERENTIAL MODE REJECTION:  
-35dB min. at 300KHz to 100MHz
  - COMMON TO COMMON MODE REJECTION:  
-30dB min. at 300MHz to 100MHz



Replace "x" with LED Color Options

	LED 2	LED 1
1	YELLOW	GREEN
2	NO LED	GREEN
3	GREEN	NO LED
4	GREEN	YELLOW
5	GREEN	GREEN
6	YELLOW	YELLOW
7	ORANGE/GREEN	ORANGE/GREEN
8	YELLOW/GREEN	YELLOW/GREEN
9	RED	NO LED
A	GREEN/YELLOW	GREEN/YELLOW
B	RED/GREEN	RED/GREEN
C	RED/GREEN	GREEN/YELLOW
D	GREEN	GREEN/YELLOW
E	YELLOW	GREEN/YELLOW

PART NUMBER	GOLD PLATING CONTACT AREA
MJS-188-K0LH-95/7xCA	3µ"
MJS-188-K0LH-96/7xCA	6µ"
MJS-188-K0LH-97/7xCA	15µ"
MJS-188-K0LH-98/7xCA	30µ"
MJS-188-K0LH-9H/7xCA	50µ"

**SPECIFICATION**

**MATERIALS**

Insulator: PBT UL 94V-0  
 Contact: 0.35mm Copper Alloy plated with Gold, and Tin in solder area  
 Shield: Copper Alloy, Nickel plated  
 Operating Temperature: 0°C to ~ +70°C



UNIT	mm	GENERAL TOLERANCE		DRAWN	DATE	DWG. NO.	SHEET 1/1
SCALE	Free	X.° ±	X. ±	Ronny	27.06.2012	1342516	REV. A
		.X° ±	.X ± 0.25	Andres	27.06.2012	SERIES NO.	
		.XX° ±	.XX ± 0.15	Hogi	27.06.2012	MJS-188-K0LH-9x/7xCA	
		.XXX° ±	.XXX ± 0.075				

**RJ45 PCB JACK <8P/8C>**  
 side entry, long profile Type with LED  
 fully shielded, with Grd. Latches around  
**H Type** 10/100/1000 Mbps, TX Filtered

REV.	DESCRIPTION	DATE	DRAWN
A	NEW	25.09.2012	Ryan

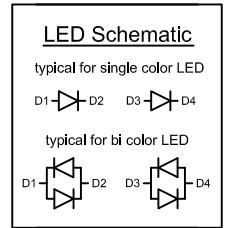
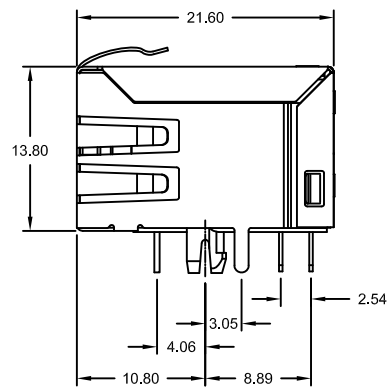
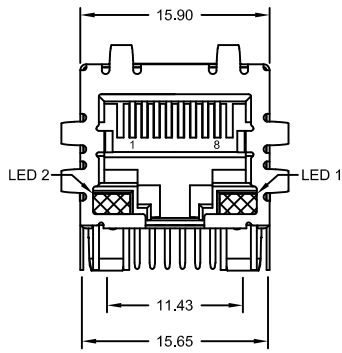

Schematic: "2" Type

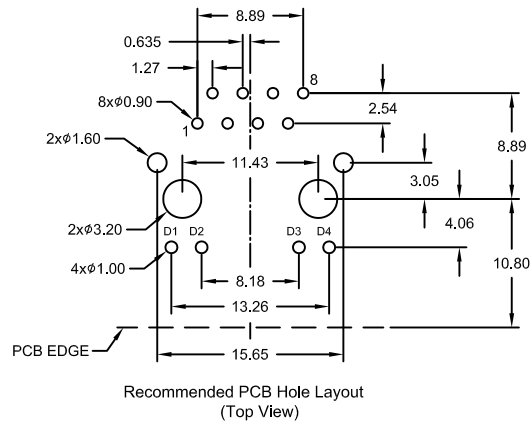
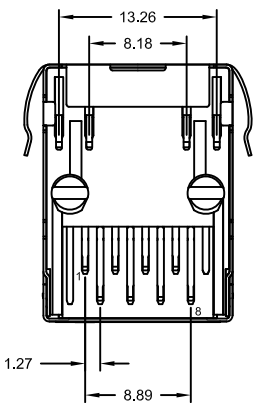
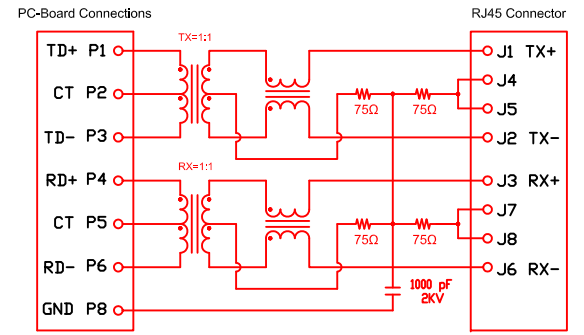

ELECTRICAL CHARACTERISTICS

- Test Notes: (25°C ±5°C)
- TR: (100KHz 0.1V):  
Pins: (P1-P3):(J1-J2)=1:1±3%  
Pins: (P4-P6):(J3-J6)=1:1±3%
  - LX: (100KHz 100mV 8mA DC Bias)  
Pins: (P1-P3):(P4-P6)=350µH min.
  - DCR:  
Pins: (J1-J2):(J3-J6)=1.2Ω max.
  - HIPOT:  
Pins: (P1-P3)to(J1,J2)=1500V AC for 60 Sec.  
Pins: (P4-P6)to(J3,J6)=1500V AC for 60 Sec.
  - INSERTION LOSS:  
-1.0dB max. at 0.3MHz to 100MHz
  - RETURN LOSS:  
-18dB min. at 1MHz to 30MHz, load 100Ω  
-16dB min. at 30MHz to 60MHz, load 100Ω  
-12dB min. at 60MHz to 80MHz, load 100Ω
  - CROSS TALK:  
-30dB min. at 1MHz to 100MHz
  - COMMON TO COMMON MODE REJECTION:  
-30dB min. at 1MHz to 100MHz

SPECIFICATION

MATERIALS

Insulator: PBT UL 94V-0  
Contact: Phosphor Bronze t=0.35mm  
plated with Gold, and Tin in solder area  
Shield: Brass, Nickel plated  
Operating Temperature: 0°C to ~ +70°C

Replace "x" with LED Color Options

LED Color Options	
LED 2	LED 1
1	YELLOW GREEN
2	NO LED GREEN
3	GREEN NO LED
4	GREEN YELLOW
5	GREEN GREEN
6	YELLOW YELLOW
7	ORANGE/GREEN ORANGE/GREEN
8	YELLOW/GREEN YELLOW/GREEN
9	RED NO LED
A	GREEN/YELLOW GREEN/YELLOW
B	RED/GREEN RED/GREEN
C	RED/GREEN GREEN/YELLOW
D	GREEN GREEN/YELLOW
E	YELLOW GREEN/YELLOW

PART NUMBER	GOLD PLATING CONTACT AREA
MJS-188-K0L2-95/7xCA	3µ"
MJS-188-K0L2-96/7xCA	6µ"
MJS-188-K0L2-97/7xCA	15µ"
MJS-188-K0L2-98/7xCA	30µ"
MJS-188-K0L2-9H/7xCA	50µ"



UNIT	SCALE	GENERAL TOLERANCE	DRAWN	DATE	DWG. NO.	SHEET 1/1
mm	Free	X.° ± X. ±	Ryan	25.09.2012	1342518	REV. A
		.X° ± .XX ± 0.25	Andres	25.09.2012	SERIES NO.	
		.XX° ± .XXX ± 0.15	Hogi	25.09.2012	MJS-188-K0L2-9x/7xCA	
		.XXX° ± .XXX ± 0.075				

**RJ45 PCB JACK <8P/8C> Tab down**  
side entry, long profile Type with LED fully shielded, with Grd. Latches around **2Type** 10/100 Mbps, 4 core TX Filtered

REV.	DESCRIPTION	DATE	DRAWN
A	NEW	23.07.2009	Eric
B	PN -MOL7- -> K0L71 : add DWG, No.	11.03.2013	Ronny
C	RoHS update	16.03.2015	Ronny

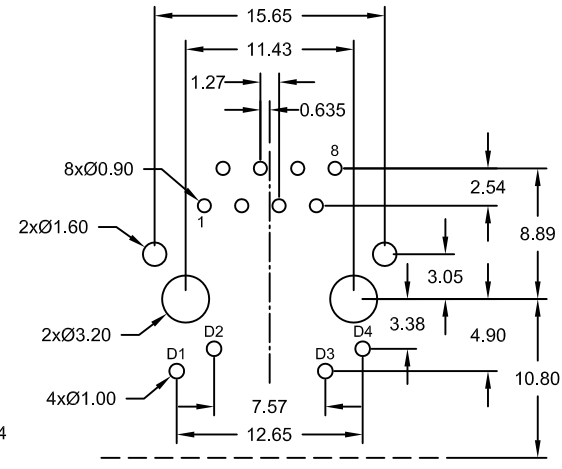
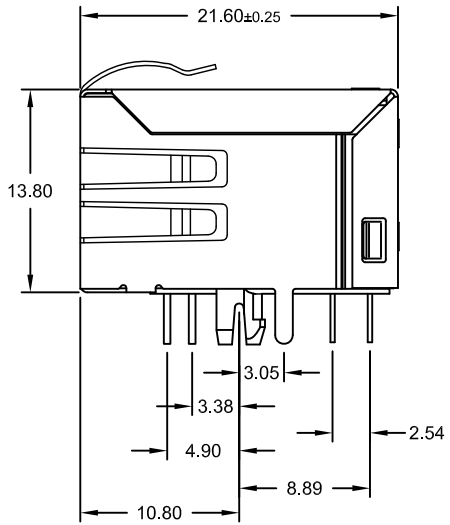
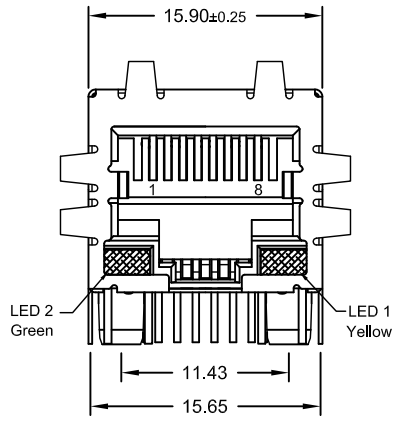

Recommended PCB Hole Layout  
(Top View)

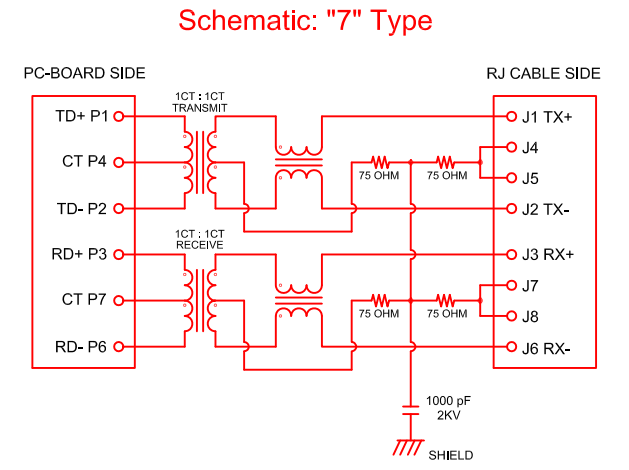

### ELECTRICAL CHARACTERISTICS

- Test Notes: (25°C ±5°C)
- TR: (100KHz 0.1V):  
Pins: (P1-P2):(J1-J2)=1:1±3%  
Pins: (P3-P6):(J3-J6)=1:1±3%
  - LX: (100KHz 100mV 8mA DC Bias)  
Pins: (P1-P2):(P3-P6)=350µH min.
  - DCR:  
Pins: (J1-J2):(J3-J6)=1.2Ω max.
  - HIPOT:  
Pins: (P1,P4,P2)to(J1,J2)=1500V AC for 60 Sec.  
Pins: (P3,P7,P6)to(J3,J6)=1500V AC for 60 Sec.
  - INSERTION LOSS:  
-1.0dB max. at 0.3MHz to 100MHz
  - RETURN LOSS:  
-20dB min. at 1MHz to 30MHz  
-15dB min. at 30MHz to 60MHz  
-10dB min. at 60MHz to 80MHz
  - CROSS TALK:  
-30dB min. at 1MHz to 100MHz
  - COMMON TO COMMON MODE REJECTION:  
-30dB min. at 1MHz to 100MHz

### LED Schematic

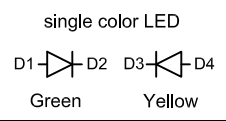

### SPECIFICATION

**MATERIALS**  
 Insulator: PBT UL 94V-0 (black)  
 Contact: Phosphor Bronze t=0.35mm plated with Gold, and Tin in solder area  
 Shield: Brass; Ni plated

Operating Temperature: 0°C to +70°C  
 Storage Temperature: -40°C to +85°C

Cavity comply with FCC Rules and Regulations Part 68, Subpart F

PART NUMBER	GOLD PLATING CONTACT AREA
MJS-188-K0L71-95/74CA	3µ"
MJS-188-K0L71-96/74CA	6µ"
MJS-188-K0L71-97/74CA	15µ"
MJS-188-K0L71-98/74CA	30µ"
MJS-188-K0L71-9H/74CA	50µ"



UNIT	GENERAL TOLERANCE		DRAWN	DATE	DWG. NO.	SHEET 1/1
mm	X.° ±	X. ±	Eric	23.07.2009	1342521	REV. C
SCALE	.X° ±	.X ± 0.25	CHECK	DATE	SERIES NO.	
Free	.XX° ±	.XX ± 0.15	Ronny	16.03.2016	MJS-188-K0L71-9x/7xCA	
	.XXX° ±	.XXX ± 0.075	APPROVE	DATE		
			Hogi	16.03.2016		

**Single Port RJ45 <8P8C> "TAB down"**  
 side entry long profile Type **with LED**  
 fully shielded with Grd. Latches around  
**"7" Type** 10/100 Base 4 core TX Filtered  
**PBT Material**

REV.	DESCRIPTION	DATE	DRAWN
A	NEW	07.03.2013	Ryan Chou

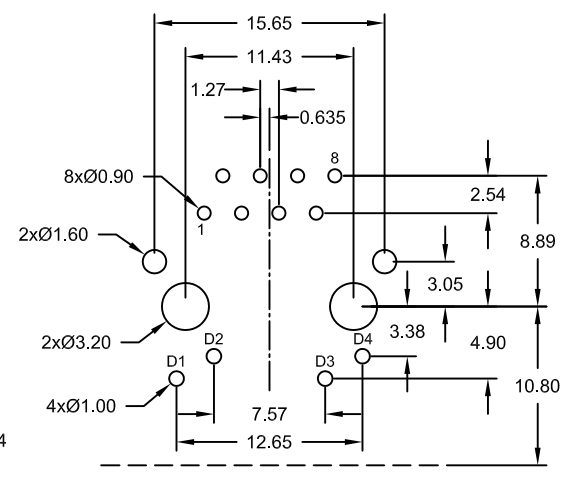
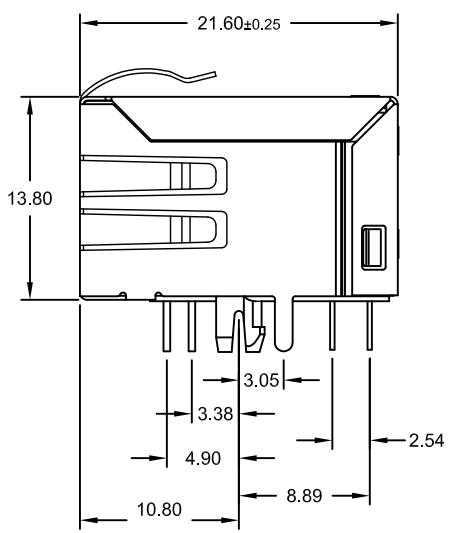
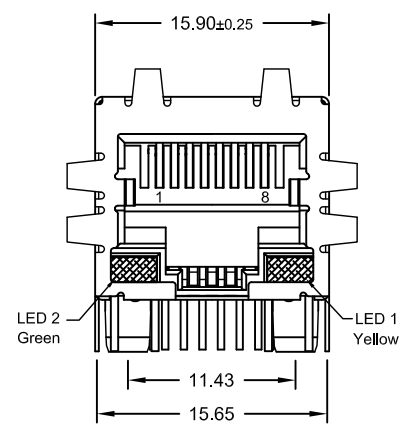

Recommended PCB Hole Layout  
(Top View)

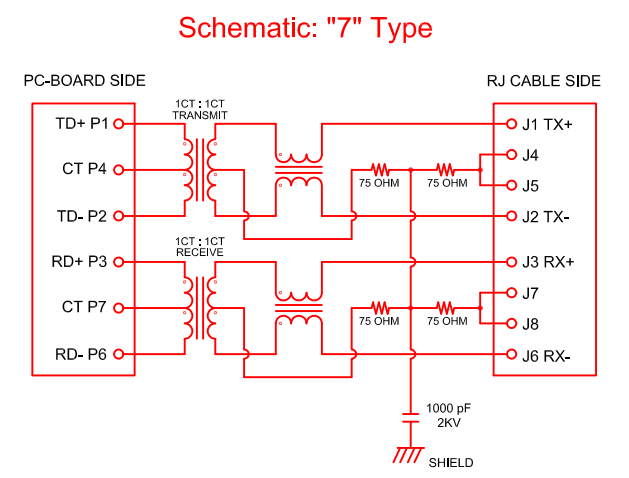

### ELECTRICAL CHARACTERISTICS

- Test Notes: (25°C ±5°C)
- TR: (100KHz 0.1V):  
Pins: (P1-P2):(J1-J2)=1:1±3%  
Pins: (P3-P6):(J3-J6)=1:1±3%
  - LX: (100KHz 100mV 8mA DC Bias)  
Pins: (P1-P2):(P3-P6)=350µH min.
  - DCR:  
Pins: (J1-J2):(J3-J6)=1.2Ω max.
  - HIPOT:  
Pins: (P1,P4,P2)to(J1,J2)=1500V AC for 60 Sec.  
Pins: (P3,P7,P6)to(J3,J6)=1500V AC for 60 Sec.
  - INSERTION LOSS:  
-1.0dB max. at 0.3MHz to 100MHz
  - RETURN LOSS:  
-20dB min. at 1MHz to 30MHz  
-15dB min. at 30MHz to 60MHz  
-10dB min. at 60MHz to 80MHz
  - CROSS TALK:  
-30dB min. at 1MHz to 100MHz
  - COMMON TO COMMON MODE REJECTION:  
-30dB min. at 1MHz to 100MHz

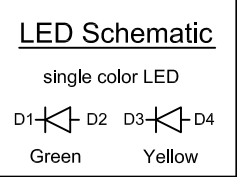

### SPECIFICATION

**MATERIALS**  
 Insulator: Nylon UL 94V-0  
 Contact: Phosphor Bronze t=0.35mm plated with Gold, and Tin in solder area  
 Shield: Stainless Steel

Operating Temperature: 0°C to +70°C  
 Storage Temperature: -40°C to +85°C

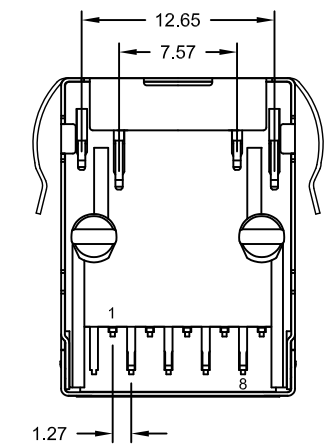

PART NUMBER	GOLD PLATING CONTACT AREA
MJS-188-K0L72-95/74CA	3µ"
MJS-188-K0L72-96/74CA	6µ"
MJS-188-K0L72-97/74CA	15µ"
MJS-188-K0L72-98/74CA	30µ"
MJS-188-K0L72-9H/74CA	50µ"



UNIT	SCALE	GENERAL TOLERANCE	DRAWN	DATE	DWG. NO.	SHEET 1/1
mm	Free	X.° ± X. ±	Ryan Chou	07.03.2013	1342522	REV. A
		.X° ± .XX ± 0.15	Ronny	07.03.2013	SERIES NO.	
		.XXX° ± .XXX ± 0.075	Hogi	07.03.2013	MJS-188-K0L72-9x7xCA	

**Single Port RJ45 <8P8C> "TAB down"**  
 side entry long profile Type **with LED**  
 fully shielded with Grd. Latches around  
**"7" Type** 10/100 Base 4 core TX Filtered  
**Nylon Material**



REV.	DESCRIPTION	DATE	DRAWN
A	NEW	25.09.2012	Ryan

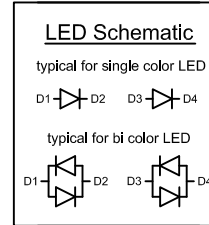
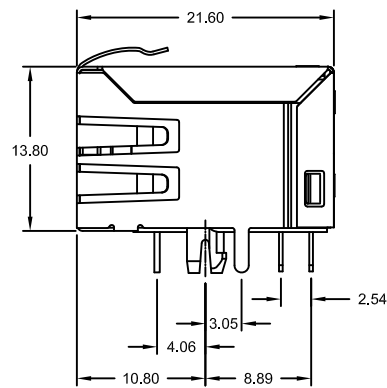
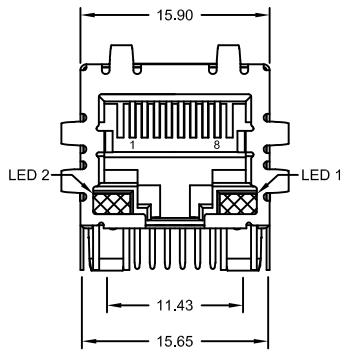

### Schematic: "J" Type

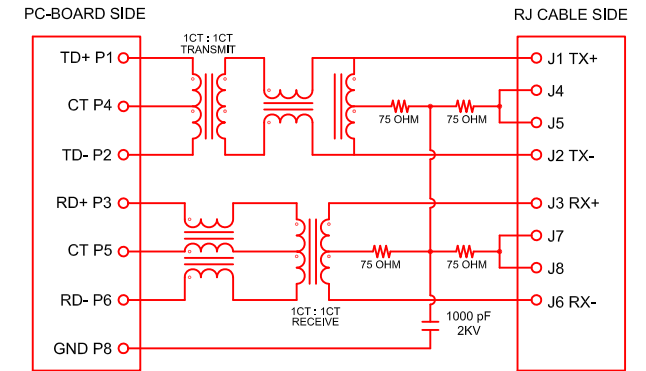

### ELECTRICAL CHARACTERISTICS

- Test Notes: (25°C ±5°C)
- TR: (100KHz 0.1V):  
Pins: (P1-P2):(J1-J2)=1:1±3%  
Pins: (P3-P6):(J3-J6)=1:1±3%
  - LX: (100KHz 100mV 8mA DC Bias)  
Pins: (P1-P2),(P3-P6)=350µH min.
  - DCR:  
Pins: (J1-J2),(J3-J6)=1.2Ω max.
  - HIPOT:  
Pins: (P1,P2)to(J1,J2)=1500V AC for 60 Sec.  
Pins: (P3,P6)to(J3,J6)=1500V AC for 60 Sec.
  - INSERTION LOSS:  
-1.0dB max. at 1MHz to 100MHz
  - RETURN LOSS:  
-18dB min. at 1MHz to 30MHz, load 100Ω  
-16dB min. at 30MHz to 60MHz, load 100Ω  
-12dB min. at 60MHz to 80MHz, load 100Ω
  - CROSS TALK:  
-30dB min. at 1MHz to 100MHz
  - COMMON TO COMMON MODE REJECTION:  
-30dB min. at 1MHz to 100MHz



### SPECIFICATION

#### MATERIALS

Insulator: PBT UL 94V-0  
Contact: Phosphor Bronze t=0.35mm  
plated with Gold, and Tin in solder area  
Shield: Brass, Nickel plated  
Operating Temperature: 0°C to ~ +70°C

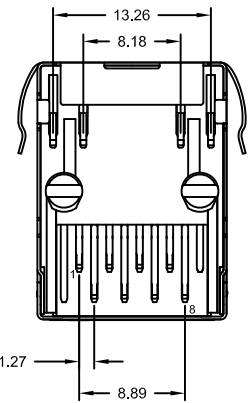
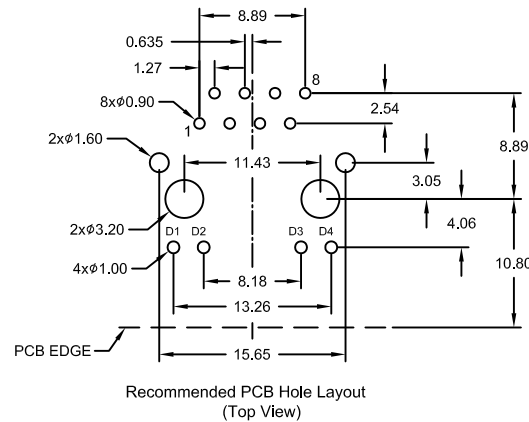

Replace "x" with LED Color Options

PART NUMBER	GOLD PLATING CONTACT AREA
MJS-188-K0LJ-95/7xCA	3µ"
MJS-188-K0LJ-96/7xCA	6µ"
MJS-188-K0LJ-97/7xCA	15µ"
MJS-188-K0LJ-98/7xCA	30µ"
MJS-188-K0LJ-9H/7xCA	50µ"

	LED Color Options	
	LED 2	LED 1
1	YELLOW	GREEN
2	NO LED	GREEN
3	GREEN	NO LED
4	GREEN	YELLOW
5	GREEN	GREEN
6	YELLOW	YELLOW
7	ORANGE/GREEN	ORANGE/GREEN
8	YELLOW/GREEN	YELLOW/GREEN
9	RED	NO LED
A	GREEN/YELLOW	GREEN/YELLOW
B	RED/GREEN	RED/GREEN
C	RED/GREEN	GREEN/YELLOW
D	GREEN	GREEN/YELLOW
E	YELLOW	GREEN/YELLOW



UNIT	SCALE	GENERAL TOLERANCE	DRAWN	DATE	DWG. NO.	SHEET 1/1
mm	Free	X.° ± X. ±	Ryan	25.09.2012	1342523	REV. A
		.X° ± .XX ± 0.25	Andres	25.09.2012	SERIES NO.	
		.XX° ± .XXX ± 0.15	Hogi	25.09.2012	MJS-188-K0LJ-9x/7xCA	
		.XXX° ± .XXX ± 0.075				

**RJ45 PCB JACK <8P/8C> Tab down**  
side entry, long profile Type with LED fully shielded, with Grd. Latches around "J" Type 10/100 Mbps, 5 core TX Filtered

REV.	DESCRIPTION	DATE	DRAWN
A	NEW	25.09.2012	Ryan

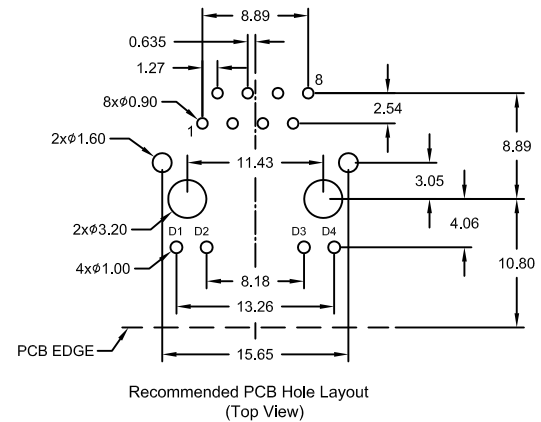
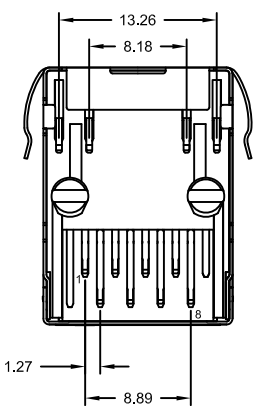
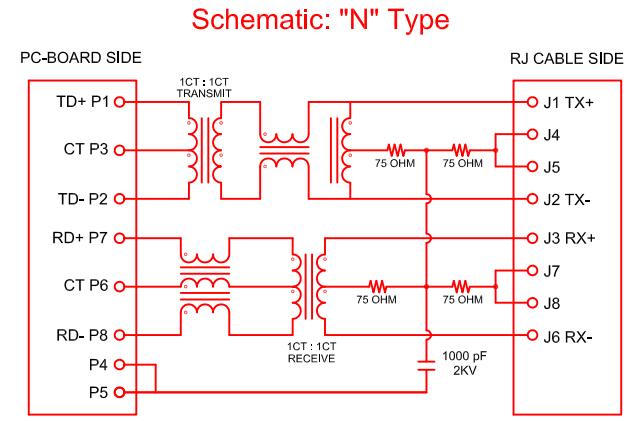
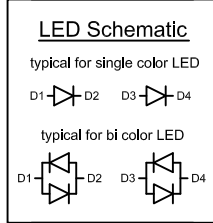
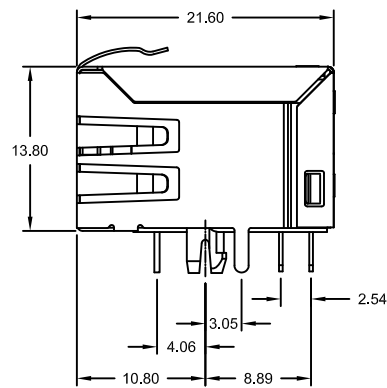
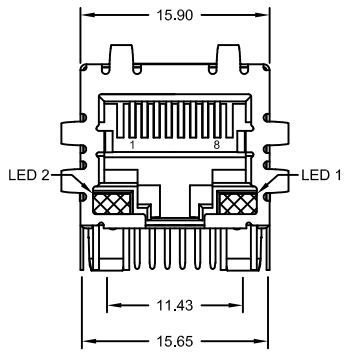

**ELECTRICAL CHARACTERISTICS**

- Test Notes: (25°C ±5°C)
1. TR: (100KHz 0.1V):  
Pins: (P1-P2):(J1-J2)=1:1±3%  
Pins: (P7-P8):(J3-J6)=1:1±3%
  2. LX: (100KHz 100mV 8mA DC Bias)  
Pins: (P1-P2),(P7-P8)=350µH min.
  3. DCR:  
Pins: (J1-J2),(J3-J6)=1.2Ω max.
  4. HIPOT:  
Pins: (P1,P2)to(J1,J2)=1500V AC for 60 Sec.  
Pins: (P4,P6)to(J3,J6)=1500V AC for 60 Sec.
  5. INSERTION LOSS:  
-1.0dB max. at 1MHz to 100MHz
  6. RETURN LOSS:  
-18dB min. at 1MHz to 30MHz, load 100Ω  
-16dB min. at 30MHz to 60MHz, load 100Ω  
-12dB min. at 60MHz to 80MHz, load 100Ω
  7. CROSS TALK:  
-30dB min. at 1MHz to 100MHz
  8. COMMON TO COMMON MODE REJECTION:  
-30dB min. at 1MHz to 100MHz

**SPECIFICATION**

**MATERIALS**

Insulator: PBT UL 94V-0  
Contact: Phosphor Bronze t=0.35mm  
plated with Gold, and Tin in solder area  
Shield: Brass, Nickel plated  
Operating Temperature: 0°C to ~ +70°C

Replace "x" with LED Color Options

LED Color Options	
LED 2	LED 1
1	YELLOW GREEN
2	NO LED GREEN
3	GREEN NO LED
4	GREEN YELLOW
5	GREEN GREEN
6	YELLOW YELLOW
7	ORANGE/GREEN ORANGE/GREEN
8	YELLOW/GREEN YELLOW/GREEN
9	RED NO LED
A	GREEN/YELLOW GREEN/YELLOW
B	RED/GREEN RED/GREEN
C	RED/GREEN GREEN/YELLOW
D	GREEN GREEN/YELLOW
E	YELLOW GREEN/YELLOW

PART NUMBER	GOLD PLATING CONTACT AREA
MJS-188-K0LN-95/7xCA	3µ"
MJS-188-K0LN-96/7xCA	6µ"
MJS-188-K0LN-97/7xCA	15µ"
MJS-188-K0LN-98/7xCA	30µ"
MJS-188-K0LN-9H/7xCA	50µ"



UNIT	SCALE	GENERAL TOLERANCE	DRAWN	DATE	DWG. NO.	SHEET 1/1
mm	Free	X.° ± X. ±	Ryan	08.05.2013	1342524	REV. A
		.X° ± .XX ± 0.25	Andres	08.05.2013	SERIES NO.	
		.XX° ± .XXX ± 0.15	Hogi	08.05.2013	MJS-188-K0LN-9x/7xCA	
		.XXX° ± .XXX ± 0.075				

**RJ45 PCB JACK <8P/8C> Tab down**  
side entry, long profile Type with LED fully shielded, with Grd. Latches around "N" Type 10/100 Mbps, 5 core TX Filtered

REV.	DESCRIPTION	DATE	DRAWN
A	New	10.01.2014	Ryan
B	update & LED schematic corrections	02.12.2015	Ronny

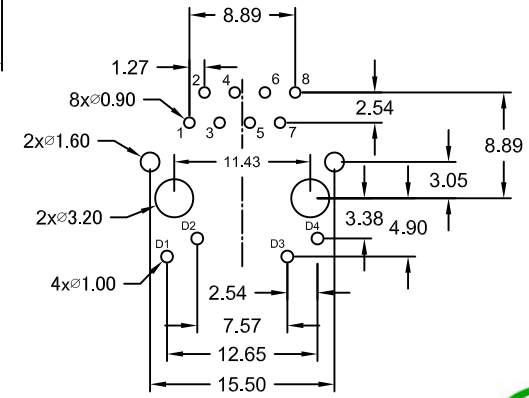
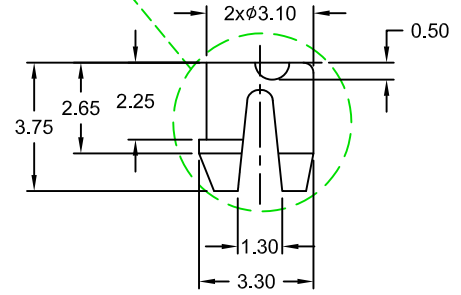
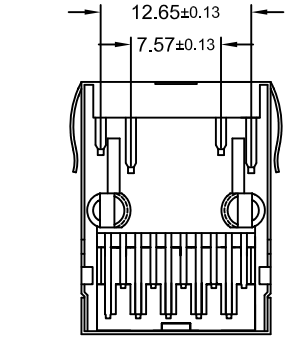
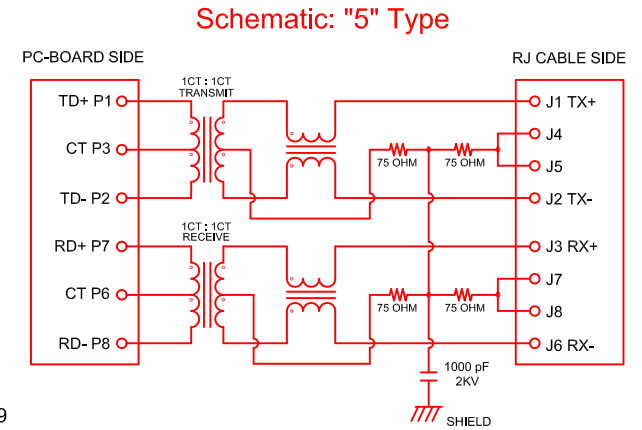
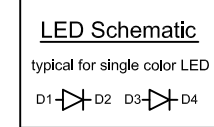
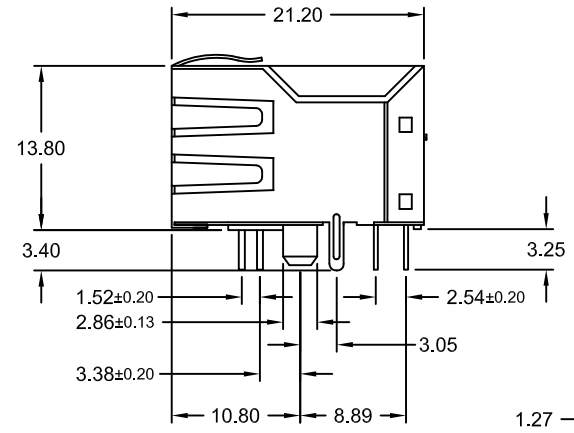
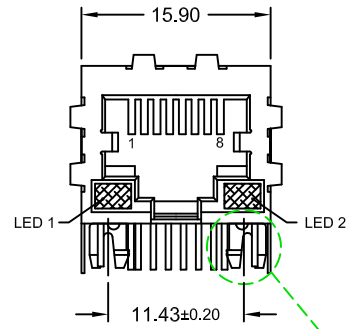

Recommended PCB Layout Top View  
(Tolerance ±0.05)



**Electrical Characteristics**

- Test Notes: (25°C ±5°C)
- TR: (100KHz 0.1V):  
Input to Output = 1:1±3%  
Pins: (P7-P8):(J3-J6)=1:1±3%
  - LX: (100KHz 100mV, 8mA, DC Bias)  
Transformer = 350µH min.
  - DCR:  
every RJ pair = 1.2Ω max.
  - HIPOT:  
Input to Output = 1500V AC for 60 Sec.
  - INSERTION LOSS:  
-1.0dB max. at 1MHz to 100MHz
  - RETURN LOSS:  
-20dB min. at 1MHz to 30MHz  
-15dB min. at 30MHz to 60MHz  
-10dB min. at 60MHz to 80MHz
  - CROSS TALK:  
-30dB min. at 1MHz to 100MHz
  - COMMON TO COMMON MODE REJECTION:  
-30dB min. at 1MHz to 100MHz

**Specifications**

**Material**  
Housing: PBT UL 94V-0 (black)  
Contact: Phosphor Bronze t=0.35mm  
Plating: Au on solder area;  
Au on contact area  
entire contact Ni underplated  
Shield: Brass t=0.20mm; Ni plated

Storage temperature: -40°C to +85°C  
Operating temperature: 0°C to +70°C

Operating life: 750 cycles min.

Cavity comply with FCC Rules and Regulations Part 68, Subpart F

Replace "x" with LED Color Options

PART NUMBER	GOLD PLATING CONTACT AREA
MJS-188-K3L5-55/7xCA	3µ"
MJS-188-K3L5-56/7xCA	6µ"
MJS-188-K3L5-57/7xCA	15µ"
MJS-188-K3L5-58/7xCA	30µ"
MJS-188-K3L5-5H/7xCA	50µ"

	LED Color Options	
	LED 2	LED 1
1	YELLOW	GREEN
2	NO LED	GREEN
3	GREEN	NO LED
4	GREEN	YELLOW
5	GREEN	GREEN
6	YELLOW	YELLOW
9	RED	NO LED

E-tec 2015 © - all rights reserved



UNIT	GENERAL TOLERANCE		DRAWN	DATE	DWG. NO.	SHEET 1/1
mm	X.° ±	X. ±	Ryan	10.01.2014	1342529	REV. B
SCALE	.X° ±	.X ±	CHECK	DATE	SERIES NO.	
Free	.XX° ±	.XX ± 0.25	Ronny	02.12.2015	MJS-188-K3L5-xx/7xCA	
	.XXX° ±	.XXX ±	APPROVE	DATE		
			Hogi	02.12.2015		

**RJ45 PCB JACK <8P/8C> "Tab down"**  
side entry, long profile Type with LED fully shielded, with gnd. Latches around Type "5" 10/100 Mbps 4 core TX Filtered

REV.	DESCRIPTION	DATE	DRAWN
A	NEW	15.04.2014	Ryan

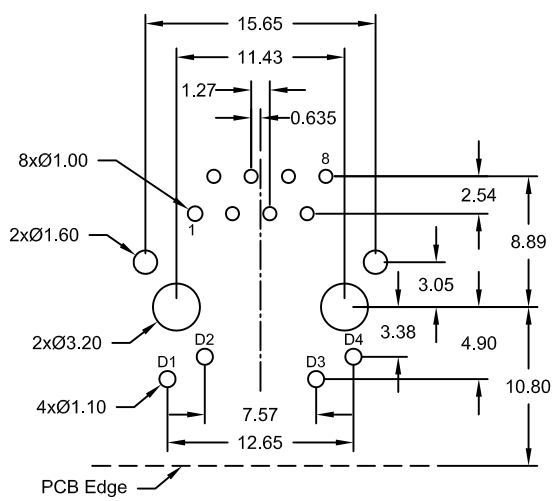
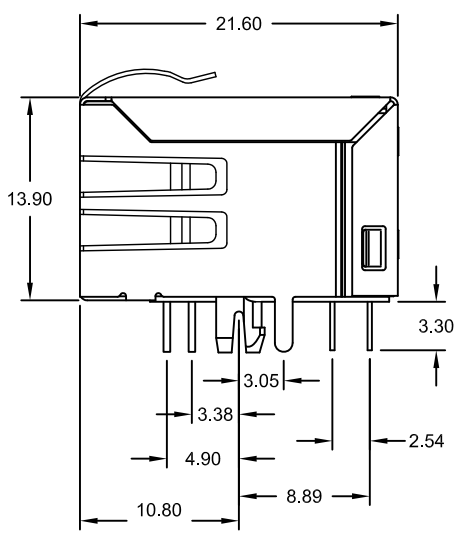
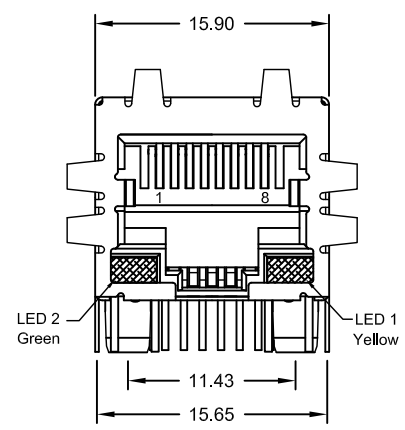

Recommended PCB Hole Layout Top View  
(Tolerance ±0.05)

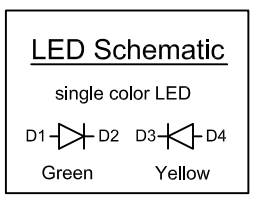
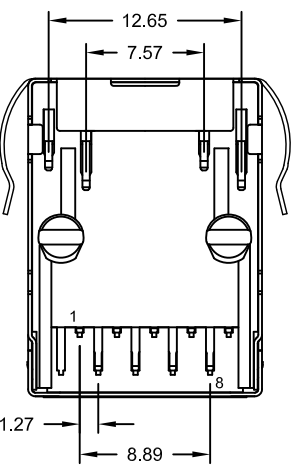
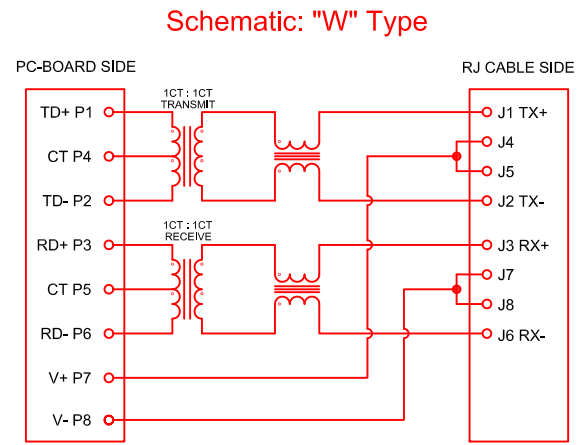

**SPECIFICATION**

**MATERIALS**  
 Insulator: PBT UL 94V-0 (black)  
 Contact: Phosphor Bronze t=0.35mm plated with Gold, and Tin in solder area  
 Shield: Brass; Ni plated

Operating Temperature: 0°C to +70°C  
 Storage Temperature: -40°C to +85°C

Cavity conform to FCC rules and Registration par68, subparts F

**ELECTRICAL CHARACTERISTICS**

- Test Notes: (25°C ±5°C)
- TR: (100KHz 0.1V):  
 Pins: (P1-P2):(J1-J2)=1:1±3%  
 Pins: (P3-P6):(J3-J6)=1:1±3%
  - LX: (100KHz 100mV 8mA DC Bias)  
 Pins: (P1-P2):(P3-P6)=350µH min.
  - DCR:  
 Pins: (J1-J2):(J3-J6)=1.2Ω max.
  - HIPOT:  
 Pins: (P1,P2)to(J1,J2)=1500V AC for 60 Sec  
 or 2250V DC for 60 Sec.  
 Pins: (P3,P6)to(J3,J6)=1500V AC for 60 Sec  
 or 2250V DC for 60 Sec.
  - INSERTION LOSS:  
 -1.0dB max. at 1MHz to 100MHz
  - RETURN LOSS:  
 -18dB min. at 1MHz to 30MHz, load 100Ω  
 -16dB min. at 30MHz to 60MHz, load 100Ω  
 -12dB min. at 60MHz to 80MHz, load 100Ω
  - CROSS TALK:  
 -30dB min. at 1MHz to 100MHz
  - COMMON TO COMMON MODE REJECTION:  
 -30dB min. at 1MHz to 100MHz

PART NUMBER	GOLD PLATING CONTACT AREA
MJS-188-K0LW-95/74CA	3µ"
MJS-188-K0LW-96/74CA	6µ"
MJS-188-K0LW-97/74CA	15µ"
MJS-188-K0LW-98/74CA	30µ"
MJS-188-K0LW-9H/74CA	50µ"

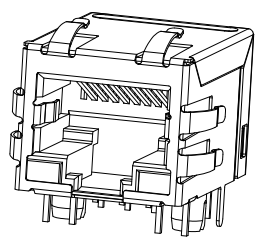

UNIT	SCALE	GENERAL TOLERANCE	DRAWN	DATE	DWG. NO.	SHEET 1/1
mm	Free	X.° ± X. ±	Ryan	15.04.2014	1342530	REV. A
		.X° ± .XX ± 0.25	Ronny	15.04.2014	SERIES NO.	
		.XXX° ± .XXX ±	Hogi	15.04.2014	MJS-188-K0LW-9x/7xCA	

**Single Port RJ45 <8P8C> "TAB down"**  
 side entry long profile Type with LED  
 fully shielded with Grd. Latches around  
**"W" Type** 10/100 Base 4 core TX Filtered

REV.	DESCRIPTION	DATE	DRAWN
A	NEW	22.08.2014	Ryan

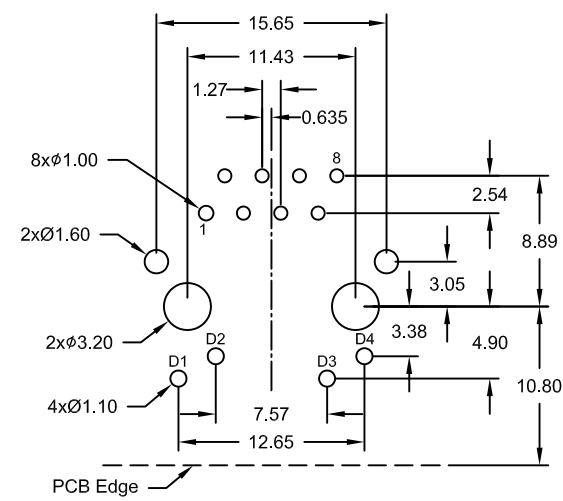
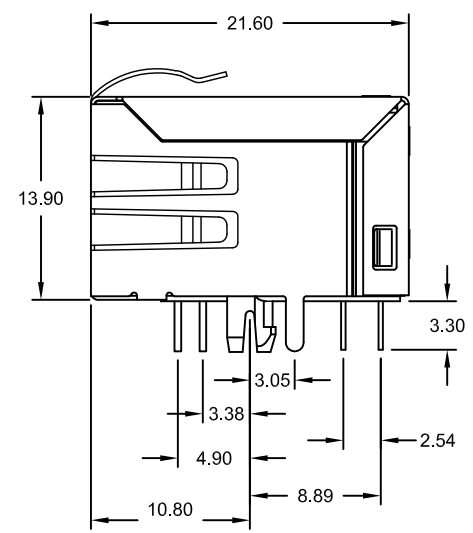
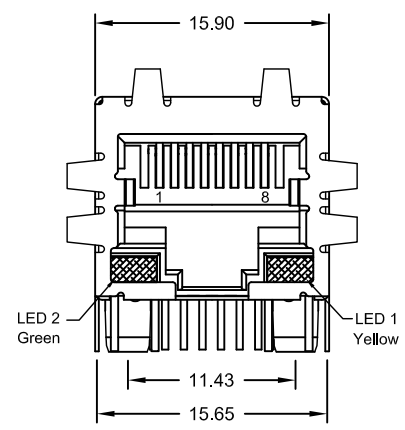

Recommended PCB Hole Layout Top View  
(Tolerance ±0.05)

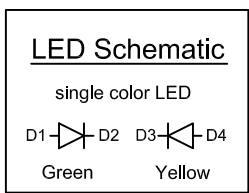
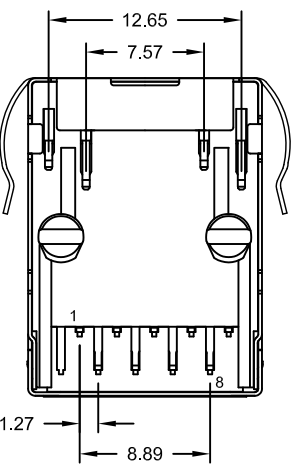
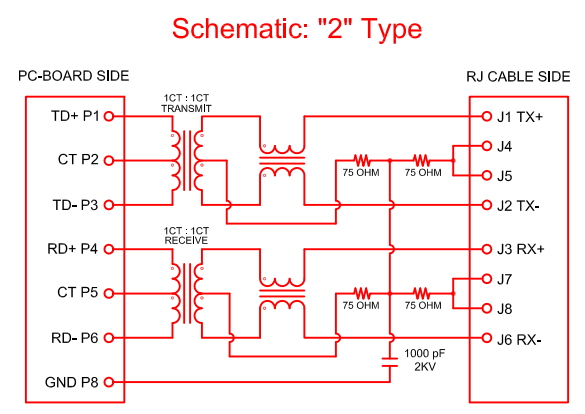

**SPECIFICATION**

**MATERIALS**  
Insulator: PBT UL 94V-0 (black)  
Contact: Phosphor Bronze t=0.35mm plated with Gold, and Tin in solder area  
Shield: Brass; Ni plated

Operating Temperature: 0°C to +70°C  
Storage Temperature: -40°C to +85°C

Cavity conform to FCC rules and Registration par68, subparts F

**ELECTRICAL CHARACTERISTICS**

- Test Notes: (25°C ±5°C)
- TR: (100KHz 0.1V):  
Pins: (P1-P3):(J1-J2)=1:1±3%  
Pins: (P4-P6):(J3-J6)=1:1±3%
  - LX: (100KHz 100mV 8mA DC Bias)  
Pins: (P1-P3):(P4-P6)=350µH min.
  - DCR:  
Pins: (J1-J2):(J3-J6)=1.2Ω max.
  - HIPOT:  
Pins: (P1,P2,P3)to(J1,J2)=1500V AC for 60 Sec.  
Pins: (P4,P5,P6)to(J3,J6)=1500V AC for 60 Sec.
  - INSERTION LOSS:  
-1dB max. at 0.3MHz to 100MHz
  - RETURN LOSS:  
-20dB min. at 1MHz to 30MHz  
-15dB min. at 30MHz to 60MHz  
-10dB min. at 60MHz to 80MHz
  - CROSS TALK:  
-30dB min. at 1MHz to 100MHz
  - COMMON TO COMMON MODE REJECTION:  
-30dB min. at 1MHz to 100MHz

PART NUMBER	GOLD PLATING CONTACT AREA
MJS-188-K0L21-95/74CA	3µ"
MJS-188-K0L21-96/74CA	6µ"
MJS-188-K0L21-97/74CA	15µ"
MJS-188-K0L21-98/74CA	30µ"
MJS-188-K0L21-9H/74CA	50µ"

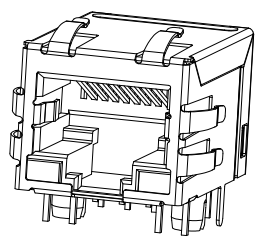

UNIT	GENERAL TOLERANCE	DRAWN	DATE	DWG. NO.	SHEET 1/1
mm	X.° ± X. ±	Ryan	22.08.2014	1342531	REV. A
SCALE	.X° ± .X ±	CHECK	DATE	SERIES NO.	
Free	.XX° ± .XX ± 0.25	Ronny	22.08.2014	MJS-188-K0L21-9x/7xCA	
	.XXX° ± .XXX ±	APPROVE	DATE		
		Hogi	22.08.2014		

**Single Port RJ45 <8P8C> "TAB down"**  
side entry long profile Type with LED  
fully shielded with Grd. Latches around  
"2" Type 10/100 Base 4 core TX Filtered

REV.	DESCRIPTION	DATE	DRAWN
A	NEW	25.09.2015	Ryan

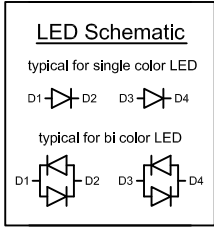
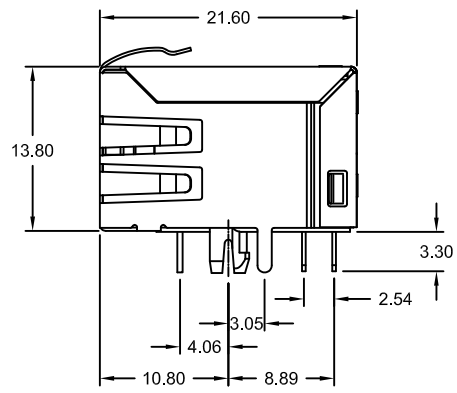
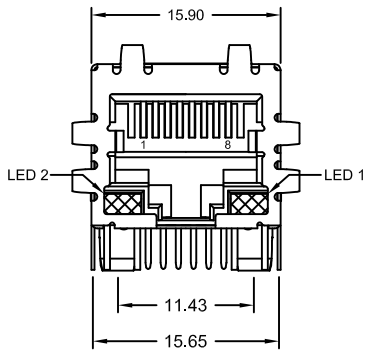

Schematic: "2" Type

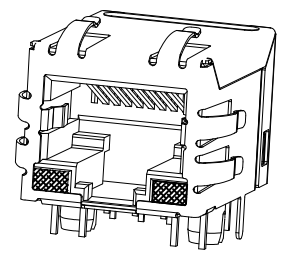
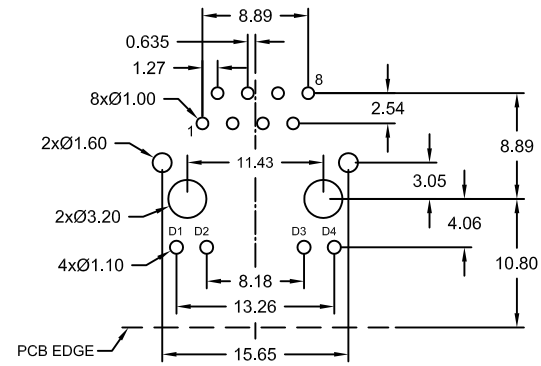
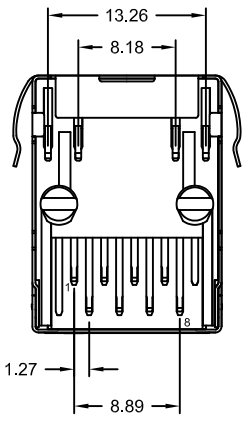
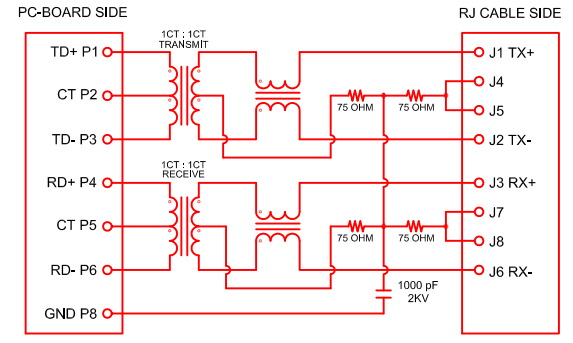

Recommended PCB Layout Top View (Tolerance ±0.05)

ELECTRICAL CHARACTERISTICS

- Test Notes: (25°C ±5°C)
- TR: (100KHz 0.1V):  
Pins: (P1-P3):(J1-J2)=1:1±3%  
Pins: (P4-P6):(J3-J6)=1:1±3%
  - LX: (100KHz 100mV 8mA DC Bias)  
Pins: (P1-P3):(P4-P6)=350µH min.
  - DCR:  
Pins: (J1-J2):(J3-J6)=1.2Ω max.
  - HIPOT:  
Pins: (P1,P3)to(J1,J2)=1500V AC for 60 Sec.  
Pins: (P4,P6)to(J3,J6)=1500V AC for 60 Sec.
  - INSERTION LOSS:  
-1.0dB max. at 0.3MHz to 100MHz
  - RETURN LOSS:  
-18dB min. at 1MHz to 30MHz, load 100Ω  
-16dB min. at 30MHz to 60MHz, load 100Ω  
-12dB min. at 60MHz to 80MHz, load 100Ω
  - CROSS TALK:  
-30dB min. at 1MHz to 100MHz
  - COMMON TO COMMON MODE REJECTION:  
-30dB min. at 1MHz to 100MHz



Specifications

**Material**  
Contact: Phosphor Bronze t=0.35mm  
Plating: Sn on solder area;  
Au on contact area  
Shield: Brass, Ni plated  
Insulator: LCP UL 94V-0  
Operating temperature: -0°C to +70°C

Cavity comply with FCC Rules and Regulations Part 68, Subpart F

Replace "x" with LED Color Options

	LED Color Options	
	LED 2	LED 1
1	YELLOW	GREEN
2	NO LED	GREEN
3	GREEN	NO LED
4	GREEN	YELLOW
5	GREEN	GREEN
6	YELLOW	YELLOW
7	ORANGE/GREEN	ORANGE/GREEN
8	YELLOW/GREEN	YELLOW/GREEN
9	RED	NO LED
A	GREEN/YELLOW	GREEN/YELLOW
B	RED/GREEN	RED/GREEN
C	RED/GREEN	GREEN/YELLOW
D	GREEN	GREEN/YELLOW
E	YELLOW	GREEN/YELLOW

PART NUMBER	GOLD PLATING CONTACT AREA
MJS-188-K0L22-95/7xCA	3µ"
MJS-188-K0L22-96/7xCA	6µ"
MJS-188-K0L22-97/7xCA	15µ"
MJS-188-K0L22-98/7xCA	30µ"
MJS-188-K0L22-9H/7xCA	50µ"

E-tec 2015 © - all rights reserved



UNIT	GENERAL TOLERANCE		DRAWN	DATE	DWG. NO.	SHEET 1/1
mm	X.° ±	X. ±	Ryan	25.09.2015	1342536	REV. A
SCALE	.X° ±	.X ±	CHECK	30.09.2015	SERIES NO.	
Free	.XX° ±	.XX ± 0.25	APPROVE	30.09.2015	MJS-188-K0L22-9x/7xCA	
	.XXX° ±	.XXX ±				

**RJ45 PCB JACK <8P/8C> "Tab down"**  
side entry, long profile Type with LED fully shielded, with Grd. Latches around **2 Type** 10/100 Mbps, 4 core TX Filtered

REV.	DESCRIPTION	DATE	DRAWN
A	New	01.12.2015	Cherry

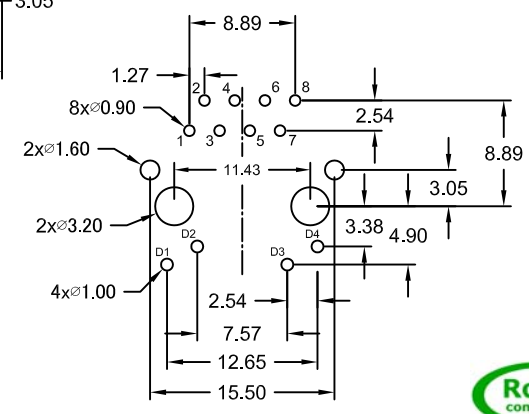
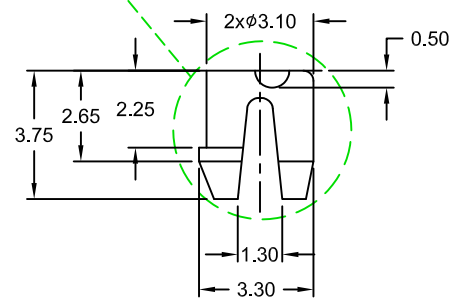
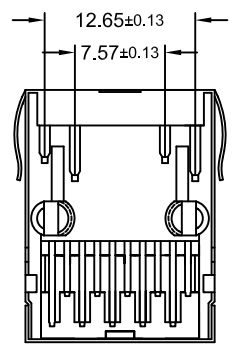
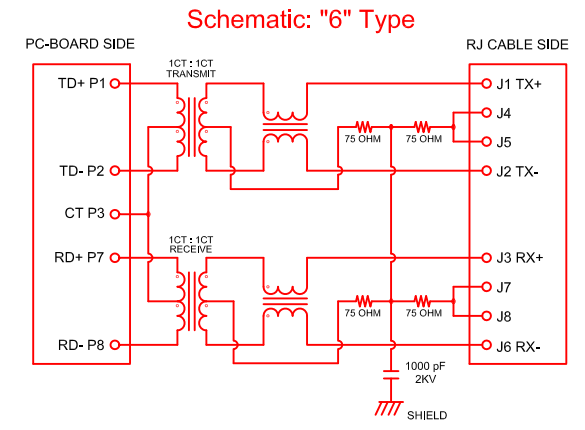
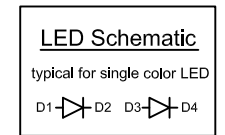
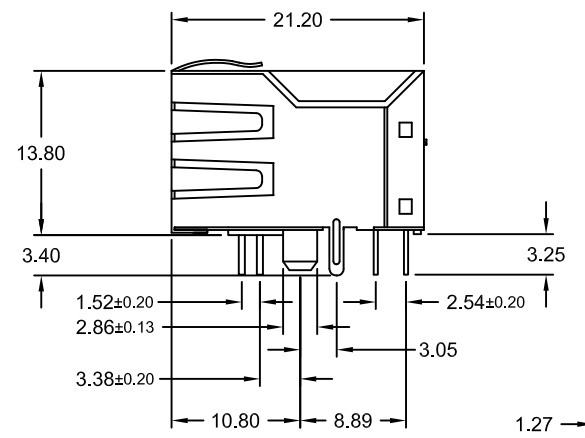
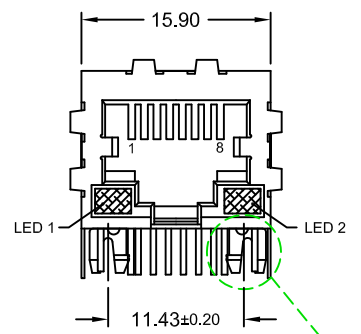

Recommended PCB Layout Top View  
(Tolerance ±0.05)

**Electrical Characteristics**

- Test Notes: (25°C ±5°C)
- TR: (100KHz 0.1V): 1:1±5%
  - LX: (100KHz 100mV 8mA DC Bias) 350µH min.
  - DCR: 1.2Ω max.
  - HIPOT: 1500V AC for 60 Sec.
  - INSERTION LOSS: -1.0dB max. at 1MHz to 100MHz
  - RETURN LOSS (100Ω ±5Ω): -16dB min. at 1MHz to 30MHz, -14dB min. at 30MHz to 40MHz, -13.5dB min. at 40MHz to 50MHz, -13dB min. at 50MHz to 60MHz, -10dB min. at 60MHz to 80MHz
  - CROSS TALK: -40dB min. at 1MHz to 30MHz, -35dB min. at 30MHz to 60MHz, -30dB min. at 60MHz to 100MHz
  - COMMON TO COMMON MODE REJECTION: -30dB min. at 1MHz to 30MHz, -25dB min. at 30MHz to 60MHz, -20dB min. at 60MHz to 125MHz

**Specifications**

**Material**  
Housing: Nylon 46 UL 94V-0 (black)  
Contact: Phosphor Bronze t=0.35mm  
Plating: Au on solder area;  
Au on contact area  
entire contact Ni underplated  
Shield: Copper Alloy t=0.20mm; Ni plated

Storage temperature: -40°C to +85°C  
Operating temperature: 0°C to +70°C

Operating life: 750 cycles min.

Cavity comply with FCC Rules and Regulations Part 68, Subpart F

Replace "x" with  
LED Color Options

PART NUMBER	GOLD PLATING CONTACT AREA
MJS-188-K3L6-55/7xCA	3µ"
MJS-188-K3L6-56/7xCA	6µ"
MJS-188-K3L6-57/7xCA	15µ"
MJS-188-K3L6-58/7xCA	30µ"
MJS-188-K3L6-5H/7xCA	50µ"

	LED Color Options	
	LED 2	LED 1
1	YELLOW	GREEN
2	NO LED	GREEN
3	GREEN	NO LED
4	GREEN	YELLOW
5	GREEN	GREEN
6	YELLOW	YELLOW
9	RED	NO LED

E-tec 2015 © - all rights reserved



UNIT	GENERAL TOLERANCE		DRAWN	DATE	DWG. NO.	SHEET 1/1
mm	X.° ±	X. ±	Cherry	01.12.2015	1342537	
SCALE	.X° ±	.X ±	CHECK	02.12.2015	SERIES NO.	REV. A
Free	.XX° ±	.XX ± 0.25	APPROVE	02.12.2015	MJS-188-K3L6-xx/7xCA	
	.XXX° ±	.XXX ±	Hogi			

**RJ45 PCB JACK <8P/8C> "Tab down"**  
side entry, long profile Type with LED  
fully shielded, with gnd. Latches around  
**Type "6"** 10/100 Mbps 4 core TX Filtered

REV.	DESCRIPTION	DATE	DRAWN
A	New	27.01.2016	Cherry

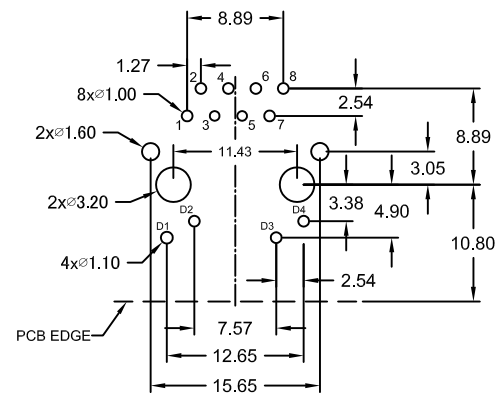
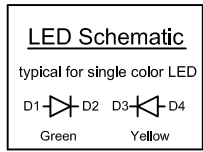
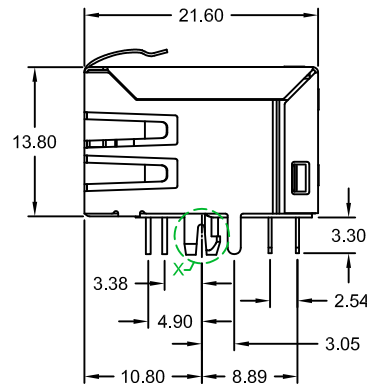
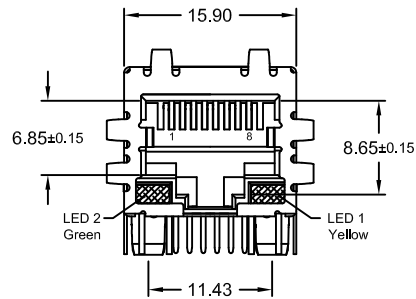

Recommended PCB Layout Top View (Tolerance ±0.05)

**Schematic: "E" Type**

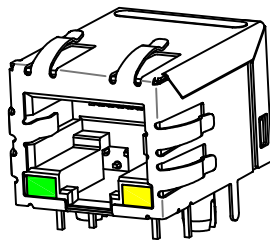
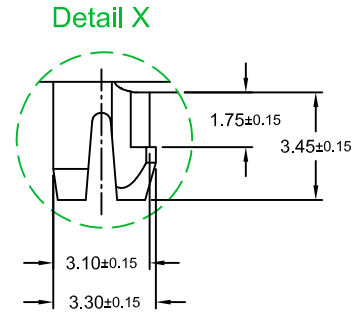
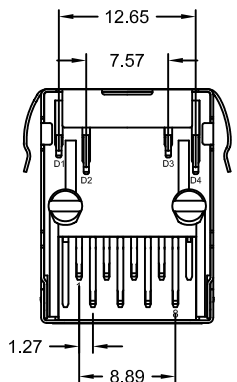
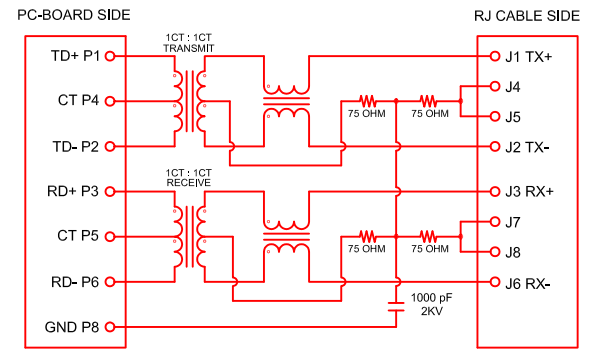

**Specifications**

**Material**  
 Housing: PBT UL 94V-0 (black)  
 Contact: Copper Alloy t=0.35mm  
 Plating: Sn on solder area;  
 Au flash on contact area  
 Shield: Copper Alloy; Ni plated

Storage temperature: -40°C to +85°C  
 Operating temperature: 0°C to +70°C

Operating life: 750 cycles min.

Cavity comply with FCC Rules and Regulations Part 68, Subpart F

**Electrical Characteristics**

- Test Notes: (25°C ±5°C)
- TR: (100KHz 0.1V):  
 Pins: (P1-P2):(J1-J2)=1:1±3%  
 Pins: (P3-P6):(J3-J6)=1:1±3%
  - LX: (100KHz 100mV 8mA DC Bias)  
 Pins: (P1-P2):(P3-P6)=350µH min.
  - DCR:  
 Pins: (J1-J2):(J3-J6)=1.2Ω max.
  - HIPOT:  
 Pins: (P1,P2)to(J1,J2)=1500V AC for 60 Sec.  
 Pins: (P3,P6)to(J3,J6)=1500V AC for 60 Sec.
  - INSERTION LOSS:  
 -1.0dB max. @ 1MHz to 100MHz
  - RETURN LOSS (100Ω ±5Ω):  
 -18dB min. @ 1MHz to 30MHz  
 -16dB min. @ 30MHz to 60MHz  
 -12dB min. @ 60MHz to 80MHz
  - CROSS TALK:  
 -30dB min. @ 1MHz to 100MHz
  - COMMON TO COMMON MODE REJECTION:  
 -30dB min. @ 1MHz to 100MHz

PART NUMBER	GOLD PLATING CONTACT AREA
MJS-188-K0LE-95/74CA	flash
MJS-188-K0LE-96/74CA	6µ"
MJS-188-K0LE-97/74CA	15µ"
MJS-188-K0LE-98/74CA	30µ"
MJS-188-K0LE-9H/74CA	50µ"

E-tec 2015 © - all rights reserved



UNIT	GENERAL TOLERANCE		DRAWN	DATE	DWG. NO.	SHEET 1/1
mm	X.° ±	X. ±	Cherry	27.01.2016	1342539	REV. A
SCALE	.X° ±	.X ±	CHECK	27.01.2016	SERIES NO.	
Free	.XX° ±	.XX ± 0.25	Ronny		MJS-188-K0LE-9x/74CA	
	.XXX° ±	.XXX ±	APPROVE	27.01.2016		
			Hogi			

**RJ45 PCB JACK <8P/8C> "Tab down"**  
 side entry, long profile Type with LED  
 fully shielded, with gnd. Latches around  
**Type "E"** 10/100 Mbps 4 core TX Filtered



REV.	DESCRIPTION	DATE	DRAWN
A	New	13.10.2016	Cherry

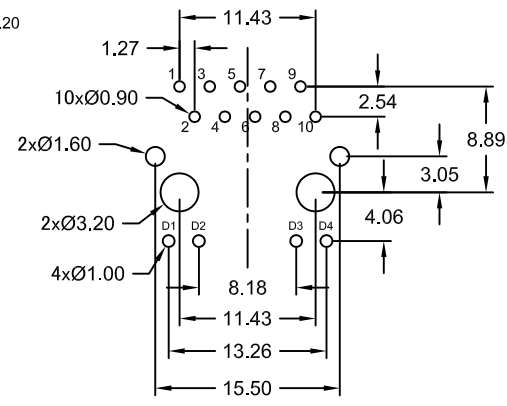
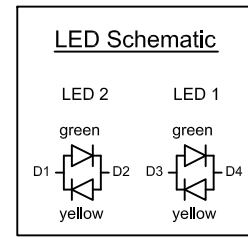
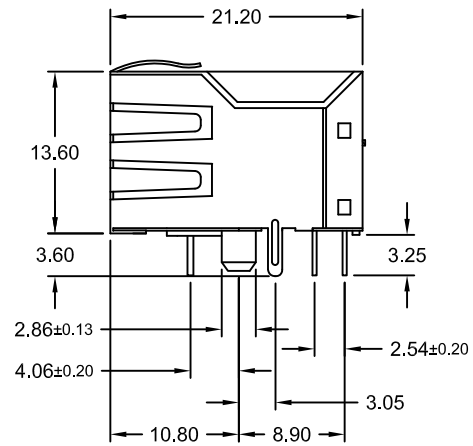
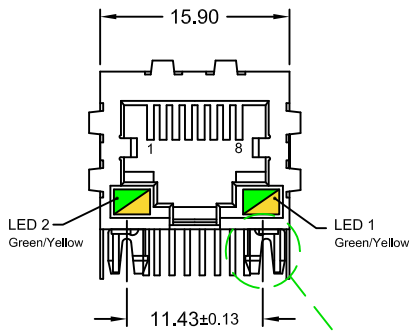

### Schematic: "AG" Type

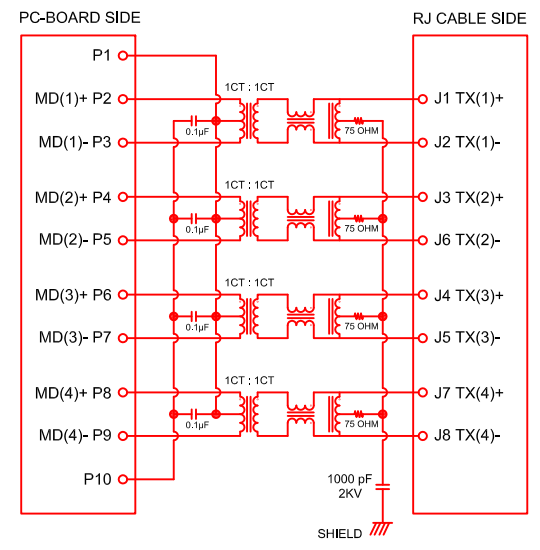

### Electrical Characteristics

- Test Notes: (25°C ±5°C)
- TR: (100KHz 0.1V):  
1CT:1CT ±5%
  - LX: (100KHz 100mV 8mA DC Bias)  
350µH min.
  - DCR:  
1.2Ω max.
  - HIPOT:  
1250V AC for 60 Sec.
  - INSERTION LOSS:  
-1.0dB max. at 1MHz to 100MHz  
-1.2dB max. at 100MHz to 125MHz
  - RETURN LOSS (100Ω ±5Ω):  
-16dB min. @ 1MHz to 40MHz, load 100Ω  
-12dB min. @ 40MHz to 60MHz, load 100Ω  
-8dB min. @ 80MHz to 100MHz, load 100Ω
  - CROSS TALK:  
-30dB min. @ 1MHz to 100MHz
  - COMMON TO COMMON MODE REJECTION:  
-30dB min. @ 1MHz to 100MHz

### Specifications

**Material**  
Housing: PBT UL 94V-0 (black)  
Contact: Phosphor Bronze t=0.35mm  
Plating: Au  
Shield: Brass t=0.20mm; Ni plated

Storage temperature: -40°C to +125°C  
Operating temperature: 0°C to +70°C

Operating life: 750 cycles min.

Cavity comply with FCC Rules and Regulations Part 68, Subpart F



PART NUMBER	GOLD PLATING CONTACT AREA
MJS-188-K3LAG-5H/7ACA	50µ"

E-tec 2016 © - all rights reserved



UNIT	GENERAL TOLERANCE	DRAWN	DATE	DWG. NO.	SHEET 1/1
mm	X.° ± X. ±	Cherry	13.10.2016	1342543	REV. A
SCALE	.X° ± .X ±	CHECK	13.10.2016	SERIES NO.	
	.XX° ± .XX ± 0.25	APPROVE	13.10.2016	MJS-188-K3Lx-5H/7ACA	
	.XXX° ± .XXX ±	Hogi			

**RJ45 PCB JACK <8P/8C> "Tab down"**  
side entry, long profile Type with LED  
fully shielded, with gnd. Latches around  
Type "AG" 10/100 Mbps 12 core TX Filtered